

Study Regarding Irrigations of Lands without Energy Consumption

BADEA LEPADATESCU
 Department of Manufacturing Engineering
 Transylvania University of Brasov
 500036 Bvd. Eroilor nr.29, Brasov,
 ROMANIA
 lepadatescu@unitbv.ro

Abstract: In many places in the plains area there are long periods of time in which there is a complete lack of water during the spring and summer periods. It is precisely during these time periods that crops need water in order to grow. However, there are many rivers flowing down these areas, which could be a potential source of water. But in these large areas there are no connections to electricity being far from the places where people live. For this reason, in the present paper are presented some constructive solutions to remove water from rivers and to direct it in the area of plant cultivation without using any conventional energy source.

Key-Words: green technology, economical solutions, irrigation, water wheel design, hydro resources.

1 Introduction

The combined utilization of Renewable Energy Sources such as wind and hydro energy is becoming increasingly attractive and is being widely used for the substitution of oil-produced energy and eventually to reduce pollution. Unlike conventional generation systems, “fuel” of wind energy and hydro energy is available at no cost.

There are a number of small isolated communities like rural villages, country houses, inaccessible farms, shelters, without access to a large electricity grid and where the absence of an electrical network in their major area or the prohibitively high connection cost, force this remote consumers to cover their urgent electrification needs to use small diesel electric generators with all the problems of pollution of environment and noise.

As it is proved by a lot of researches, it will be a very positive and economic solution the replacement of bigger part of diesel generators with stand alone HES, especially in medium and high wind and hydro energy potential.

Comparing to the other renewable energy resources, such as solar energy, wind energy has a more variable and diffuse energy flux. In order to maximize the benefit of the wind energy, it is very important to be able to describe the variation of wind velocity at a given site.

The energy available in the wind is proportional to the cube of the wind speed: if the wind speed is doubled, there is eight times the available power.

Wind turbine has many applications as:

- Stock water – sheep, cattle, horses;
- Domestic applications – household water for drinking, sanitation, and washing;
- Irrigation – for house and vegetable gardses;
- Filling dams, reservoirs, fish ponds, lakes;
- Dewatering wet lands;
- Water for small industry;
- Waste water removal;
- Sewage;
- Remote locations;

The selecting of a wind turbine should be based on the next criteria: wind conditions, source a water supply, water requirements, total pumping head, and governing.

Regarding of wind conditions, the right combination of wind turbine and pump is one which will work easily in light winds (about 10 km/h). This will also depend on the total pumping head [2].

Wind turbine will be useful for pumping water for stock and domestic supplies in isolated rural areas. It can be an economical alternative where:

- Wind conditions are reliable;
- Unattended pumping is required for long periods;
- There is no other viable power source;

- The user requires environmentally clean power;

The principal advantages of using a wind turbine are outlined below:

- run unattended for long periods;
- low maintenance;
- suits isolated locations;
- no energy costs;

Some of their disadvantages are:

- high capital costs;
- intermittent pumping in very light winds;
- requires auxiliary storage;

2 Wind Turbine with Horizontal Axis to Pump Water for Irrigation

The purpose of this paragraph is to provide knowledge about lifting irrigation water on small and medium sized land-holdings (generally in the range between 0.25 – 25 ha, which are numerous in a lot of places with small farming to increase their crop production. Some researches have shown that small land-holdings are often more productive, in terms of yield per hectare, than larger units, although they are more demanding in terms of labor inputs.

Using the water from the rivers to irrigate lands can be considered one of renewable and sustainable rural energy system because it is coming from free environment of water landscape. It is used often because of low cost of construction and operation and low maintenance since there is no need for maintenance annually or monthly.

The main shortcoming of water power as an energy resource for irrigation is that it is only available for convenient use in a limited number of locations having suitable flows and heads to engineer an effective site. Therefore, the main applications for the use of power to pump water will be in lowland areas, inevitably using low head water drops as a power source, to irrigate land which would not be accessible to gravity water flow. In some arid regions, or regions with dry seasons, there are large perennial rivers where the river current can be utilized to lift water which would otherwise flow past parched fields. Even in some wetter and more mountainous areas there are situations where water power could allow irrigation of terraces or plateau that are inaccessible to gravity flow.



Fig.1: A wind turbine with horizontal axis to pump water.

The wind is a natural resource that is available everywhere. As a general rule the wind blows for between 8 to 10 hours per day, at a speed that is useful for the wind turbine.

To achieve the needs regarding the domestic supply water was designed and realized a wind turbine with horizontal axis which is presented in Fig.1. The main parts of the wind turbine are: 1- the multiblades rotor; 2- the tower or mast made by tubular steel with two sections of pipe coupled together; 3-the guy wires attached to the tower in three points and with an underground concrete anchor for each set; 4- the diaphragm pump; 5- the concrete base;

The rotor is formed by 12 blades and has a diameter of 1, 5 m. The height of entire turbine is 6 m. The wind turbine is located at 5 m distance from the river whose water we intend to use for domestic needs.

To pump the water was chosen a diaphragm pump shown in Fig.2. The pump is acted by a cable (4) that has a reciprocating motion which is received from the rotor mechanism.

The rotor mechanism transforms the revolution motion into reciprocating motion through a cam.

In a cam operated wind turbine, the lift of the water occurs during more than one-half the cycle. Using a cam that allows for three-quarters of the cycle lifting and one-quarter return, starting torque is reduced by 60 percent.

A diaphragm pump is a pump that uses a combination of the reciprocating action of a membrane made by rubber and non return check valves to pump water. When the volume of a chamber is increased – the diaphragm moving up- the pressure decreases, and fluid is drawn into the chamber. When the chamber pressure increases from decreased volume – the diaphragm moving down- the fluid previously drawn in is forced out. After that, the diaphragm is moving up again draws fluid into the chamber, completing the cycle.

The entire perimeter of the diaphragm is tightly held and sealed in place between the side of the displacement chamber and a flange, which is tightly bolted to the chamber.

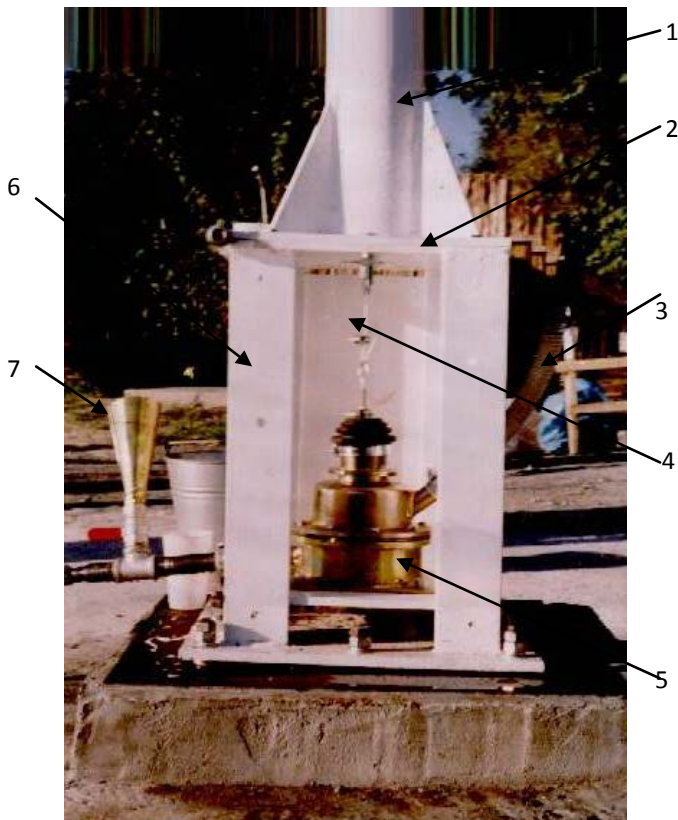

Fig.2: Diaphragm pump used to pump water.

Each displacement chamber has two valves, usually spring-loaded ball valves made from the same material as the diaphragm. One of the valves The wind turbine will start in light winds, and if

combined with counterbalancing, starting torque is reduced by 72 percent. It is a driving mechanism that flexes the diaphragm in and out of the chamber to suction in and force out the water. The water is taken from the river through the device 7 and is sending to the water tank by the flexible pipe 3. The body of the pump 7 is connected to the tower 1 by the plate 2 by a bolt and bush-bearing which helps when the mast is erected in position. The characteristic of this wind turbine are shown in Table 1.

The water is taken from the river through the device 3 and is sending to the water tank by the flexible pipe 4. The body of the pump 5 is connected to the tower 6 by the plate 7 by a bolt and bush-bearing which helps when the mast is erected in position.

Table 1. Wind turbine characteristics

Number of blades	12
Rotor diameter	2.0 m
Maximum depth of water extraction	6 m
Protection system for wind speeds higher than	12 m/s
Optimal wind speeds	3-10 m/s
Rotor height from the ground	6.5 m
Total weight	200 kg
Water flow obtained at wind speeds of 8-10 m / s	

3 Water Wheel Powered by Hydro Resource used for Irrigation

The paper present a solution to take water from the river and use it on the small and medium sized land holdings, with an area between 0.25 ha to 20 ha. Small land-holdings in this size range are most numerous in many of the developing countries, and extension of the use of irrigation in this small farming sector could bring huge benefits in increased food production and improved economic well-being. It is also hoped that this paper will be useful to those seeking techniques for lifting water for purposes other than irrigation.

One of the principal reasons to seek alternatives to petroleum fuelled engines for irrigation is because of the inability of many countries to import sufficient petroleum to meet present needs. Therefore, any system which lends itself to whole or partial local manufacture is of potential economic importance in terms of import substitution for oil and for engines too.

In this section of the paper we present a solution to irrigate lands using an undershot water wheel (also called a *stream wheel*) which is a vertically mounted

water wheel that is rotated by water striking paddles or blades at the bottom of the wheel (Fig.3).

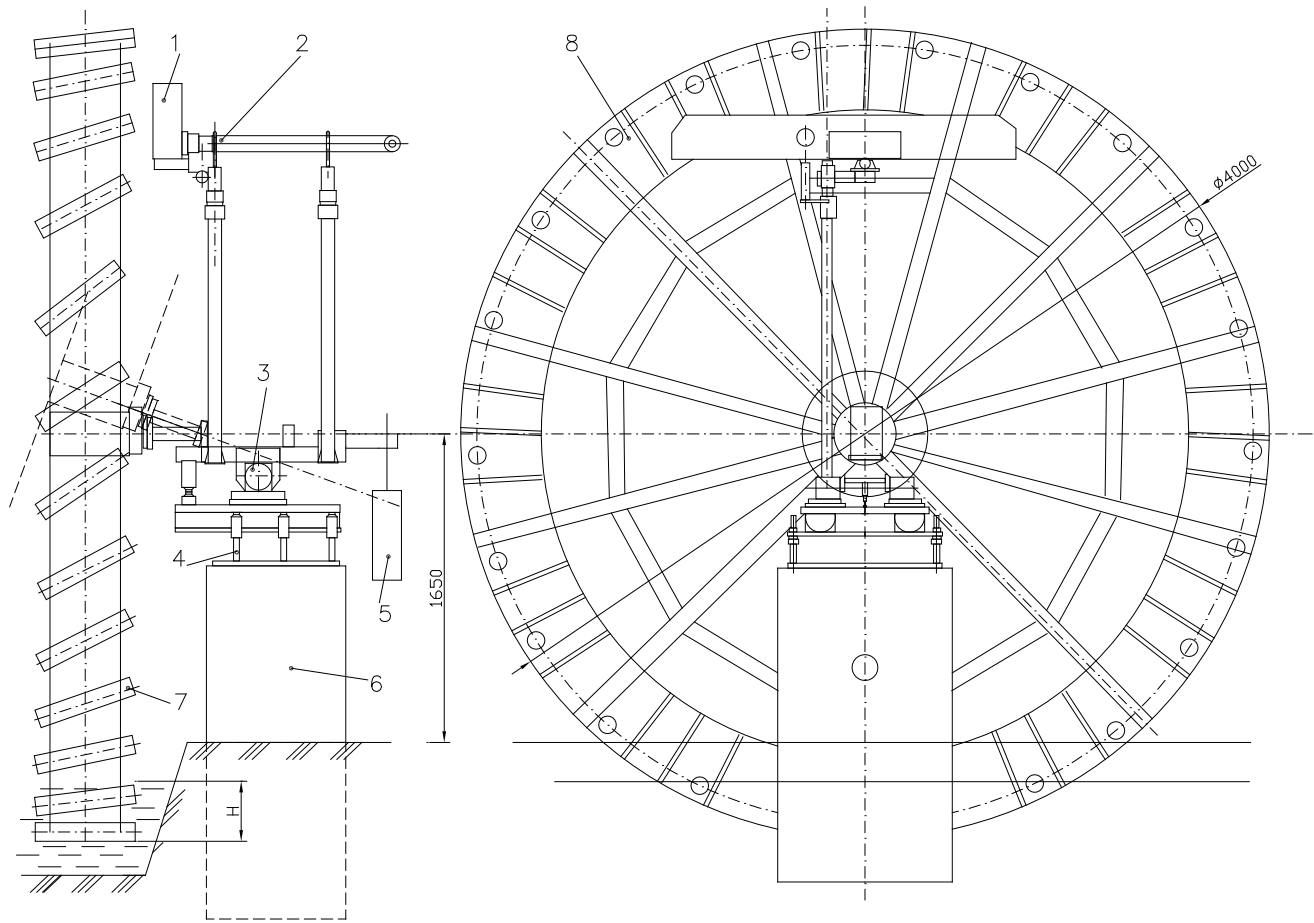

Fig.3: Sketch of an undershot water wheel used for irrigation of dry lands.

The name *undershot* comes from this striking at the bottom of the wheel. It consists of a large, very narrow undershot water wheel whose rim is made up of a series of containers which lift water from the river to a very small aqueduct at top of the wheel, using the power of flowing water to pump some of the water out of the river to an irrigation channel. It can raise water to somewhat less than its full height. This type of mechanism is axiomatically associated with dry lands where is needed more water than direct rainfall alone could provide.

The overshot wheel uses both the weight and the momentum of the water and so are more efficient and powerful.

The advantages of undershot wheels are that they are somewhat cheaper and simpler to build, and have less of an environmental impact – as they do not constitute a major change of the river. Their disadvantages are less efficiency (between 15-25%), which means that they generate less power and can only be used where the flow rate is sufficient to provide torque. Undershot wheels gain no advantage from head. They are most suited to shallow streams in flat areas. To calculate the efficiency of this water wheel of a diameter of 4 m it is used the sketch below (Fig.4), where the position of the collector tube fixed on the rotor in the time when its upper end comes out from the water.

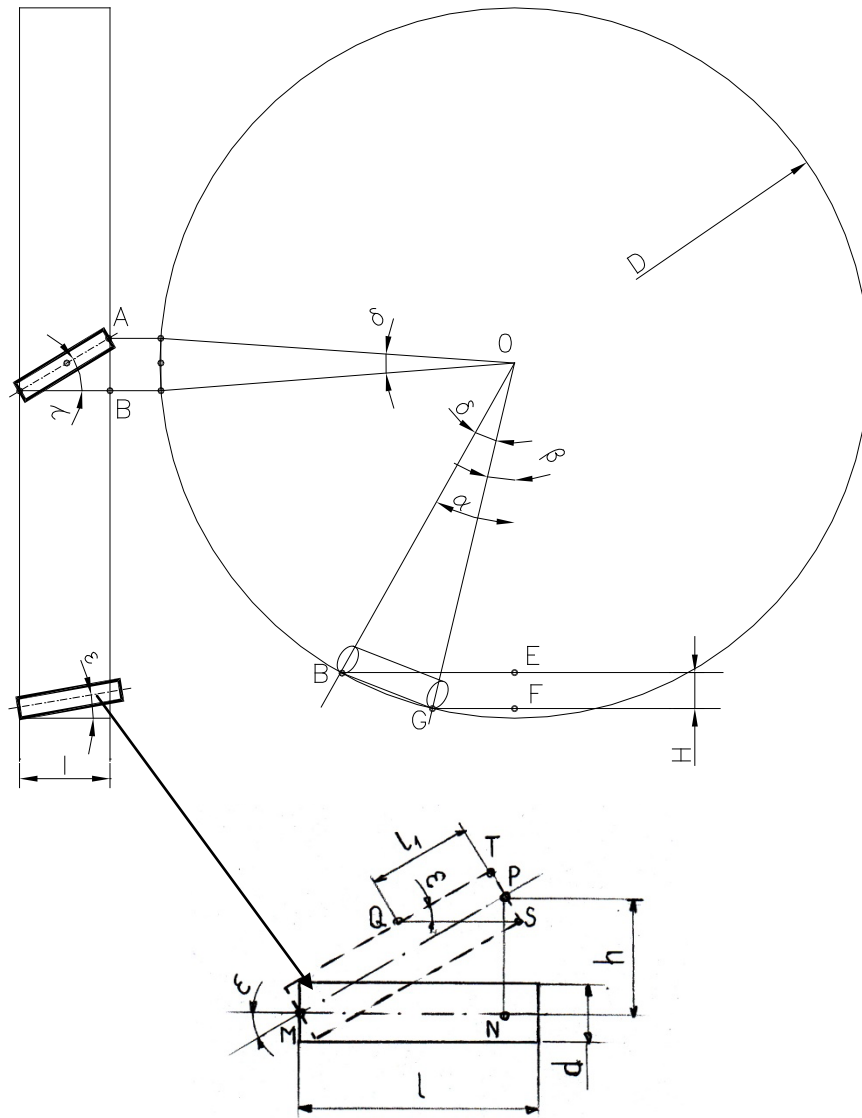

Fig.4: Calculation of the volume of water extracted from the river by a collector tube.

After a series of calculations is obtained equation (1) which shows the amount of water that is taken from the river by one tube collector. Since the rotor has 12 tube collectors, this value must be multiplied by 12 to determine the amount of water that comes to one rotation of the rotor.

$$V_2 = \frac{\pi d^2}{4} \left(l - \frac{d\sqrt{4l^2 - \{D[\cos(\alpha - \delta) - 1] + 2H\}^2}}{2\{D[\cos(\alpha - \delta) - 1] + 2H\}} \right) \quad (1)$$

where, l is the rotor width, d is the diameter of the collector tube, H is the depth of immersion of the rotor in river water, α and δ being constructive parameters.

For the next constructive elements of the rotor: $l = 500$ mm; $D = 3900$ mm; $H = 200$ mm; $\gamma = 45^\circ$; $d = 75$ mm used in experimental tests we obtain $V_2 = 1.57$ l. If we multiply by 12, the number of tubes collectors, will obtain a quantity of water extracted from the river at one rotation of the water wheel a value of 18.84 l.

An important factor for plant efficiency is the speed of the water of the river. As the speed of the water is higher the amount of water extracted by the rotor will be higher and therefore higher plant efficiency.

Volume of water extracted from the river in one minute V_{min} is given by:

$$V_{min} = n_{min} \cdot V_2, \quad (2)$$

$$V_{min} = C \cdot v_w, \quad (3)$$

where V_2 is the volume of water extracted from the river by the rotor in one rotation given by equation (1). Relation (2) can be written:

where C is a coefficient given by: $C = \frac{V_2}{\pi \cdot D}$.

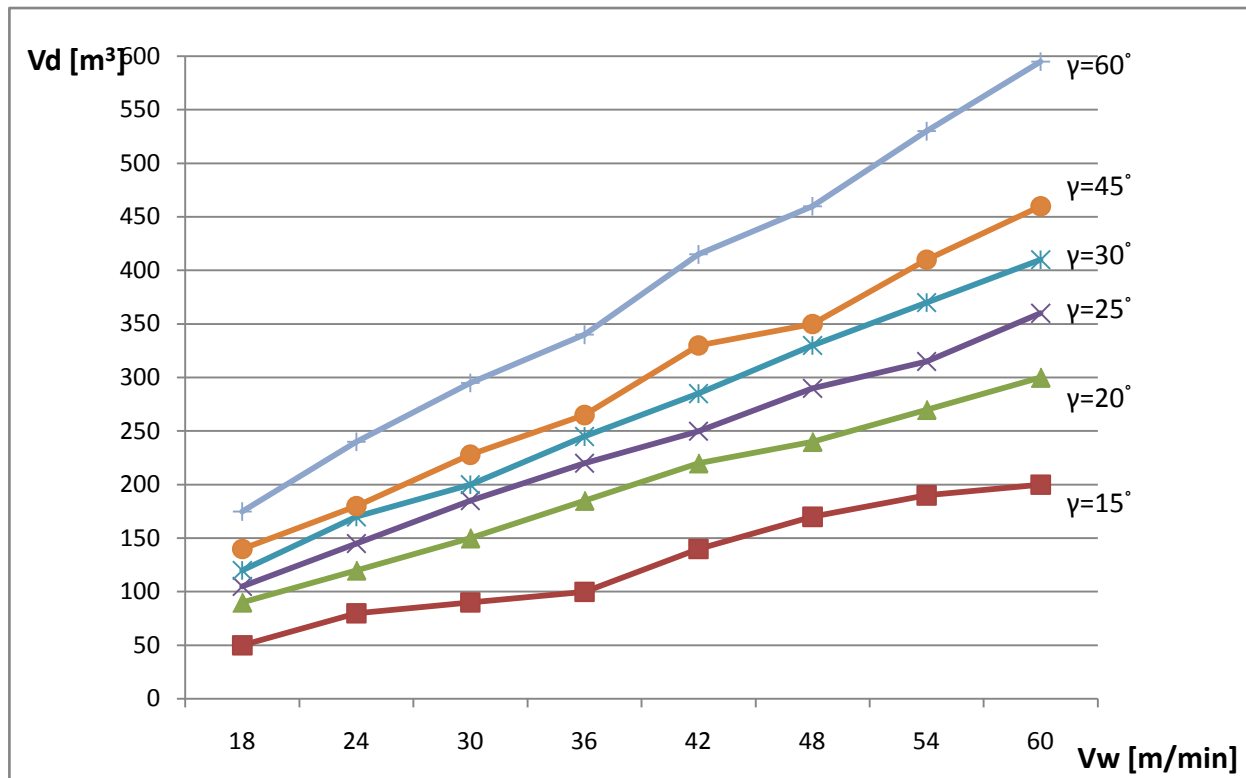

Fig.5: Dependence of the volume of water extracted from the river in a day (Vd), depending on the angle of installation of the collecting tubes on the circumference of the rotor (angle γ) and the speed of the water of the river (Vw).

Fig. 6 shows the water wheel that was made and was mounted on the edge of a river. At the installation site, the river had small dimensions, with a width of 1.5 m and a depth of 40 cm. Also

the speed of the river was of small value which led to a smaller volume of collected water.



Fig.6: Undershot water wheel mounted on the river bank.

4 Installation of the Water Wheel System from the Rivers

There are several ways to install the water wheel to extract water from rivers. A first method is to mount the installation directly on the river bank as shown in Fig.7.

This way of mounting the water wheel is cheaper, with a lower cost loan and in a shorter time. The disadvantage of this method of installation is that the proper functioning of the installation is unsafe because it depends on the flow of water in the river and the fact that the water of the river is not always clean.

I can float on the water various objects that can enter the rotor blades and damage it.

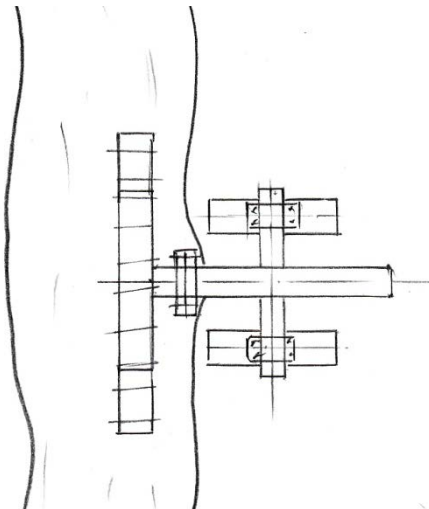

Fig.7: Mounting the installation directly on the river bank.

To overcome this disadvantage, another method of mounting the installation is presented as shown in Fig.8. In this case, a canal is built parallel to the flow direction of the river where the water is forced to pass.

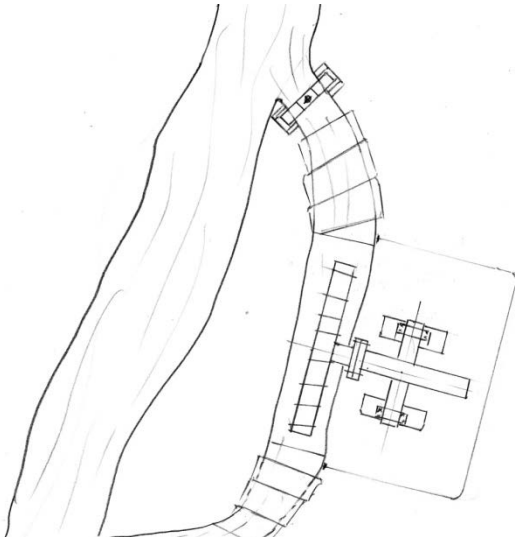

Fig.8: Mounting the installation on an Intermediate channel parallel to the river.

This channel is reinforced with a U-shaped concrete structure that will be subsequently covered with concrete slabs in areas where the water wheel does not have access. In this way the water flowing through this channel is perfectly clean because at the end of the channel entrance there is a grill that will stop all the objects that happen randomly on the water and that could reach the rotor area. Also, the water level flowing through this channel is very well regulated so that we have the certainty of a good functioning of the installation throughout the year.

To increase the efficiency of the water wheel and to extract a bigger quantity of water from the river we study the possibility of using a larger rotor, with a diameter of 10 m (Fig.9). By this way the area of land that can be used for crops in bigger and we take also in consideration to put this type of rotor on the both side of the river. In this case it is possible to increase the efficiency of the irrigation.



Fig.9: Rotor of a water wheel with a diameter of 10 m.

5 Efficiency of Water Wheels

One of the advantages of using this type of irrigate system is to function as a green technology concept having no negative effect on the environment. It has a big impact on the rural economy, increasing the productivity of the cultivated fields. The development of energy systems based on water energy resources is vital to enhance the livelihood of people and has a great potential in terms of economic impact due to its low cost, sustainability and energy renewability.

Some important result of local manufacture to produce water lifting devices in order to pump irrigation water is:

- Creation of local industrial employment;
- Enhancement of industrial skills;
- Improved local availability of spare parts;
- Improved local expertise in the technology.

Given a suitable site in proximity to a suitable need, hydro-power has a number of important and fundamental attractions:

- It is generally available 24 h/day;
- It is a relatively concentrated energy source;
- The available energy is easily predictable in areas where river flow data are available.

Hydro-power systems can be one of the most economic sources of power for those fortunate enough to have a suitable resource available

6 Conclusion

One of the advantages of using this type of irrigate system is to function as a green technology concept having no negative effect on the environment. It has a big impact on the rural economy, increasing the productivity of the cultivated fields. The development of energy systems based on water energy resources is vital to enhance the livelihood of people and has a great potential in terms of economic impact due to its low cost, sustainability and energy renewability.

In country agriculture, water use is of great importance to obtain yields proportionate to the population. Drought is a natural factor very harmful and affects a large agricultural area in total agricultural area of a country. Drought effect is observed mainly in the plains and hills

with a moisture deficit and uneven water distribution cultivated area.

The main purpose of irrigation is to supply water during the growing agricultural areas located in dry areas or in areas with unfavorable distribution of rainfall.

If are larger surface that need irrigation it can use multiple installations mounted on the river.

Some other advantages of using these types of installations for irrigate dry areas are:

- It improves general health of the villages;
- Some of the advantages of installing this system of obtaining water are listed below:
- Zero pollution;
 - Operates 24 hours a day, 7 days a week without supervision;
 - No fuel or electricity cost;
 - Low maintenance and repair cost;
 - Repairs are done locally;
 - Installation is up to 80% cheaper than other water system models;
 - Local manufacturing and training generates employment.

References:

- [1] Borza, I., - Researches regarding the influence of the plant density on yield and water use efficiency in maize crop from Crisurilor plain. University of Oradea, 2008.
- [2] W. W. Thierheimer, N. Tane. R. Gruia, L. Gaceu, D. Thierhiemer, D. Ola, M. Clinciu V., Cojocar - Reducing Environmental Pollution from Mobile Sources, In Environmental Engineering and Management Journal, December 2010, Iasi.
- [3] Hofkes E.H., Visscher J.T. - Renewable Energy Sources for Rural Water Supply in Developing Countries, International Reference Centre for Community Water Supply and Sanitation. The Hague, The Nederland, 1986.
- [4] Lopez A. - Water Related to Biorefinery and Agriculture, Conference on the Indo-European Research and Innovation Partnership, Brussels, 2014.
- [5] Prakha M.,- Sustainable energy solutions for irrigation and harvesting in developing

- countries, PhD thesis, California Institute of Technology, Pasadena, California, 2014.
- [6] Watt S.B., (1995), Manual on the Hydraulic for Pumping Water, Intermediate technology publication, London.