

Engineering Aspects and Parameter Evaluation of Ozone Generator

MOHAMED B. EL_MASHEDE¹, MAGDY M. ZAKY², A. A. SALEH³, AND M. EL_HANASH³

¹Electrical Engineering Dept., Faculty of Engineering, Al Azhar University, Nasr City, Cairo, EGYPT

²Egypt Second Research Reactor, EAEA, EGYPT

³Dept. of Nuclear Safety Research and Radiological Emergencies – NCRRT Center – EAEA.

Abstract—This paper introduces the Ozone generator parameters analysis and its engineering design aspects. Practically, Ozone is successfully used in water treatment applications; furthermore, it can be used to treat the secondary system cooling water in nuclear research reactors. The main element in this process is the Ozone generator; it has many parameters that need to be set at its design. These parameters can be divided into those related to the electrical equivalent circuit of corona dielectric barrier discharge (DBD), those associated with injected gas flow between the two electrodes, and those belonging to temperature of the electrodes. This paper is intended to those parameters that are related to the electrical equivalent circuit which has two standard models: linear and nonlinear. In this regard, the determination of the component values of nonlinear model can be achieved very hardly. To handle such determination, the nonlinear model can be approximately treated as a linear model in an approaching fashion. Based on this approximation, Lissajous plot and differential evolution (DE) methodologies are used for the computation of DBD ozone chamber parameters. Additionally, a new theoretical technique will be presented.

Key Words—Ozone generator, Resonant frequency, linear and non linear model, Lissajous plot and differential evolution (DE).

Received: January 30, 2021. Revised: March 13, 2021. Accepted: March 23, 2021. Published: March 31, 2021.

1. Introduction

In the last decade, using of Ozone in water treatment and medication become attractive due to these well recorded results from experiments and industrial applications. One of the most important applications is the water treatment; it has many benefits such as minimization of chemical materials use with better water quality. The process of Ozone generation consists of different equipments. One of them is the Ozone generator chamber, which plays the main role in the Ozone generation process. Corona discharge and dielectric barrier discharge (DBD) can be considered as the most efficient ozone generation techniques [1,2,3,4]. They have the same ozone reactor construction which consists of two conductors as electrodes having gap to allow air or oxygen to flow in between. In addition, a high voltage is applied to the electrodes to overcome the gap insulation [5]. As a result, micro discharges will be generated causing ultraviolet radiations that transform the oxygen molecules into ozone. The only difference between corona discharge and dielectric barrier discharge (DBD) is that one of the two electrodes is covered with dielectric material in the case of DBD method as shown in Fig. 1a. In addition, it is necessary to avoid the arc discharge to obtain the silent discharge [4,6]. Fig. 1b illustrates the standard equivalent circuit of the ozone reactor where the

high voltage is applied between the terminals a and b. Cd and Ca are the dielectric and air or oxygen gap capacitances, respectively. Ionization or discharge occurs at threshold condition that the charged voltage at the gap capacitor is higher than the ionization voltage Vz. The diode bridge is added to achieve the threshold condition. The ionization voltage depends primarily on the gap volume along with other parameters; pressure and temperature of the gas. The model in Fig. 1b is called nonlinear model. Since some components change their behavior around the threshold condition, it is not easy to design the power supply that drives this model.

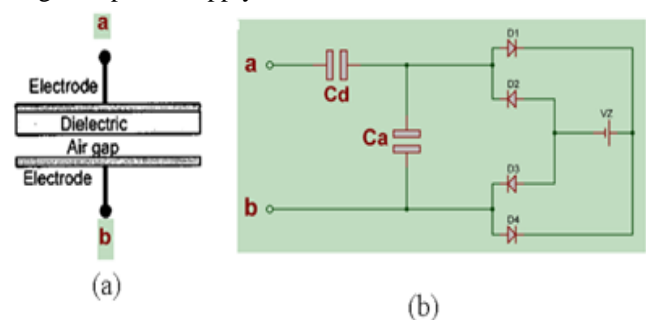

Fig. 1. a: Ozone generator construction, b: Non linear model equivalent circuit.

Fig. 2, on the other hand, demonstrates the linear model equivalent circuit, where C is the reactor capacitance and R is the discharge resistance. Lissajous plot and differential evolution (DE) procedures have been used to solve this model. Unfortunately, each one of them

depends on the operation frequency range. Lissajous plot technique is suitable for the frequency range lower than 20 KHz where this plot will be distorted above this critical value [3,7,8,9,10]. The second technique, on the other hand, uses differential evolution technique. This technique is valid for higher frequency range [11]. As the frequency increases, its results will be enhanced. Generally, the main function of these techniques is to find the ozone reactor parameters; chamber capacitance, discharge resistance and the ionization or threshold voltage. In this regard, the ionization voltage depends on the air or gas volume between the electrodes. The required energy to produce ozone gas from air ranges from 5.583kWh/m³ to 8.631kWh/m³ and 1.17243 kWh/m³ to 1.620kWh/m³ for oxygen [12]. The electric field can be evaluated via its relation with the required energy. As a result, the threshold voltage can be obtained.

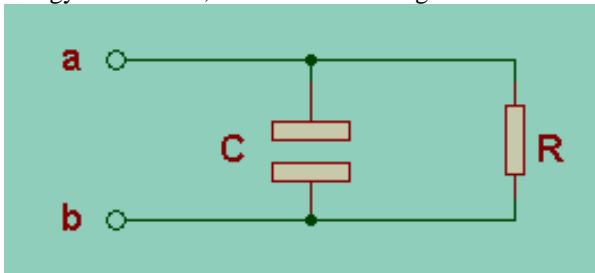

Fig. 2. Linear model equivalent circuit of the ozone reactor

2. Lissajous plot and differential evolution (DE) strategies

Lissajous plot and differential evolution (DE) methods are the most common techniques that are employed to determine the ozone generator parameters. Figure 2 is considered as a reference model for these two techniques. Lissajous plot uses the relation between the current and the voltage to determine the reactor capacitance. On the other hand, the reactor discharge resistance is calculated using the relation between the applied voltage and the charges through the discharge resistance. The maximum ozone generator efficiency and stability performance are achieved at the resonance frequency. As a result of the applied voltage between a & b in Fig. 2, the excited voltage will be purely sinusoidal. Thus,

$$V_a = V_p \sin 2\pi ft \quad (1)$$

In the above expression, V_a is the applied voltage, V_p is the voltage amplitude, f is the resonance frequency and t denotes the time. The relation between the voltage and the current of the capacitor has a formula given by:

$$\left(\frac{V_a}{V_p}\right)^2 + \left(\frac{I}{2\pi f C V_p}\right)^2 = 1 \quad (2)$$

Here, I denotes the capacitor current and c represents the generator capacitance. Fig. 3- a demonstrates the Lissajous plot between the current and the voltage of the capacitor in the frequency range (15-20 kHz) while Fig. 3-b represents the same thing for the other frequencies

outside this range. In this situation, the capacitor value can be calculated as [13,14]:

$$c = \frac{I_0}{2\pi f V_p} \quad \text{at } V_a = 0 \quad (3)$$

I_0 is the current value at zero applied voltage.

The discharge resistance value can be determined using the relation between the applied voltage and the charges that pass through it as depicted in Fig. 4. Thus,

$$\left(\frac{V_a}{V_p}\right)^2 + \left(\frac{2\pi Q f R}{V_p}\right)^2 = 1 \quad (4)$$

Q refers to the charge through the discharge resistance. Accordingly, the discharge resistance can be formulated as:

$$R = \frac{V_p}{2\pi Q_0} \quad \text{at } V_a = 0 \quad (5)$$

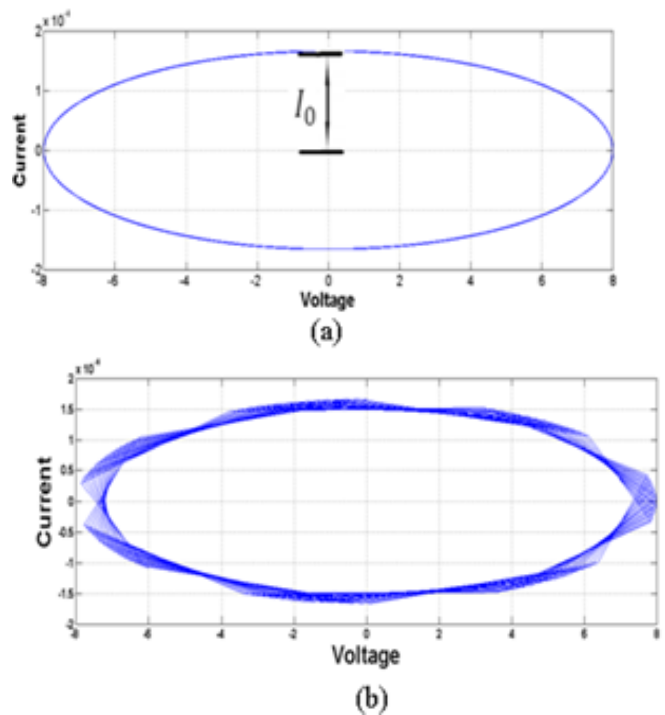

Fig. 3. Lissajous plot between (voltage and current) for (DBD) ozone generator a: 15KHz < f < 20KHz, b: 15KHz > f > 20KHz

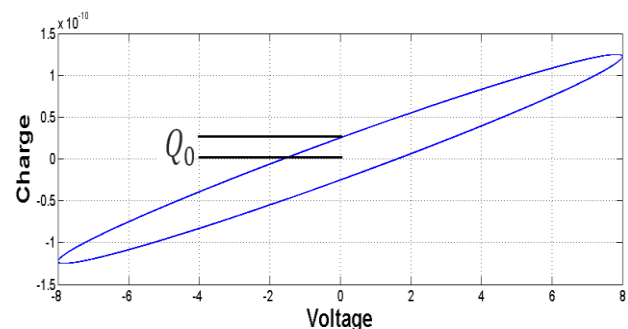

Fig. 4. Lissajous plot between (voltage and charge) for (DBD) ozone generator

Differential evolution (DE) method uses a variable inductor L that will be connected in series with the ozone chamber as Fig. 5 shows [13,14]. At resonance

frequency, the maximum voltage gain ($A_{max} = \left| \frac{V_{out}}{V_{in}} \right|$) can be expressed as:

$$A_{max} = \frac{R}{\sqrt{\frac{L}{c} - \frac{L^2}{4R^2c^2}}} \quad (6)$$

And the resonance frequency will be obtained as:

$$f = \frac{1}{2\pi} \sqrt{\frac{1}{LC} - \frac{1}{2c^2R^2}} \quad (7)$$

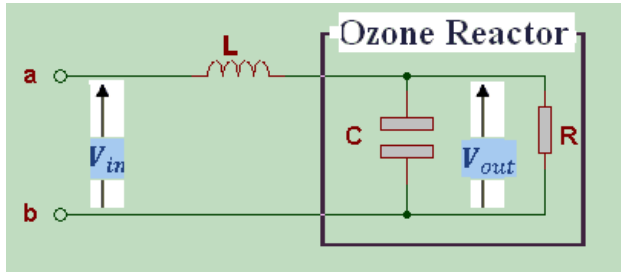

Fig. 5. An equivalent circuit of ozone reactor and variable inductor

The values of chamber capacitance and discharge resistance can be obtained using two procedures. One of them is by approaching the last two equations to become [11]:

$$A_{max} = \frac{Q_p}{\sqrt{1 - \frac{1}{4Q_p^2}}} \quad (7)$$

$$f = f_p \sqrt{1 - \frac{1}{2Q_p^2}} \quad (8)$$

Where, $f_p = \frac{1}{2\pi\sqrt{LC}}$ and $Q_p = 2\pi f_p CR$. For $Q_p \gg 1$, thus, $A_{max} \cong Q_p$ and $f \cong f_p$.

In this paper C & R will be graphically obtained without approaching. Table I demonstrates a comparison between these two methods.

TABLE I: A COMPARISON BETWEEN APPROACH AND GRAPHICAL METHODS.

f (KHz)	Q_p	L (mH)	Approach		Graphical	
			C(pF)	R(K Ω)	C(pF)	R(K Ω)
29.3	12.8	193	152.5	454.8	151	452
31.5	13	168	153	432.3	153	431
33.7	13.1	145	155	402.2	155	403
35.4	13.26	128	157	377.5	158	378
37.2	13.47	116	158	365.2	159	365

As illustrated in the table; there are no differences between approach and graphical results. Fig. 6 demonstrates obtaining the values of chamber capacitance and discharge resistance graphically for $A_{max} = 12.43$, $L = 336.7$ mH and $f = 22.8$ KHz.

3. Proposed theoretical method

Now, we are going to analyze the determination of the dielectric barrier discharge ozone generator parameters. In this regard, the ionization voltage can be calculated by determining the required ionization energy. The gap and

the dielectric capacitances will be theoretically calculated by the using of Gauss's Law.

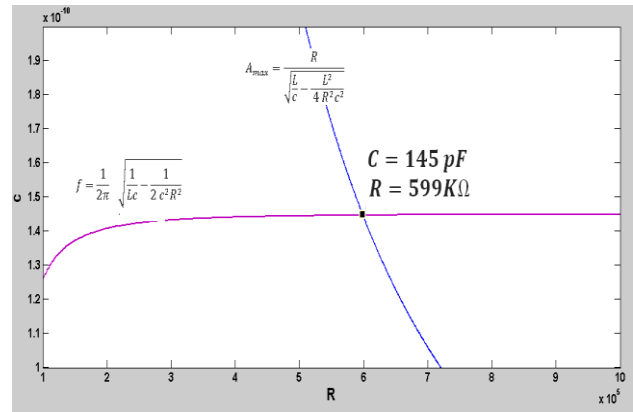

Fig. 6. Determination of capacitance and discharge resistance of ozone chamber graphically

A.3.1 The ionization threshold voltage

For co-core cylindrical ozone reactor; the electrical field has a mathematical form given by:

$$E(r) = \frac{V}{r \ln \frac{r_2}{r_1}} \quad r_1 < r < r_2 \quad (10)$$

E denotes the electric field between the two cylindrical electrodes; the value of which depends on the applied voltage V and the radius of the reactor. r_1 & r_2 represent the inner and outer cylinders radius, respectively. As Eq.(10) demonstrates, the electric field is maximized at $r = r_1$ and as a result of this, the ionization or the threshold voltage can be calculated as [8]:

$$V_{th} = \frac{E_{max}}{r_1 \ln \frac{r_2}{r_1}} \quad (11)$$

As mentioned earlier, ionization energy has a range between 1.17243 kWh/m³ and 1.620 kWh/m³ for oxygen and as a consequence of that range, the threshold voltage can be calculated from the minimum required energy (1.17243 kWh/m³). Thus, the ionization energy can be expressed as

$$W = \frac{1}{2} \iiint_{vol} \epsilon_o E^2 dv \quad (12)$$

ϵ_o is the free space permittivity, and dv is the differential volume. For co-core cylindrical ozone generator; the electric field has maximum value at the inner cylinder and minimum value at the outer one. In other words, E_{min} and E_{max} have mathematical forms given by:

$$E_{max} = \sqrt{\frac{2W_{max}}{\epsilon_o V_g}}, \quad E_{min} = \sqrt{\frac{2W_{min}}{\epsilon_o V_g}} \quad (13)$$

V_g is the gap volume between the two electrodes. For ozone generator model with inner cylindrical radius 1.45 cm, outer cylindrical radius 1.59 cm and of length 30cm, the maximum and minimum values of the electric field can be evaluated to give $E_{max} = 19.129$ KV/cm and $E_{min} = 16.273$ KV/cm [8]. The electric field flux is perpendicular to the electrode surface and therefore the required threshold voltage for 1.4 mm ionization gap is 2.28 KV.

B. 3.2 Air gap and dielectric capacitances

This section concerns with capacitance calculations of two parallel plates and co-core cylindrical ozone generators. Two parallel plates construction has two medium; one of them depends on dielectric material and the other for air or oxygen gap. The ionization gap permittivity is air or oxygen permittivity at the operating pressure and temperature. Fig. 7 illustrates the parallel plates ozone reactor construction. k_e & ϵ_0 are the relative dielectric and the ionization gap permittivities, respectively, whilst t & d are the dielectric and air gap thicknesses, respectively.

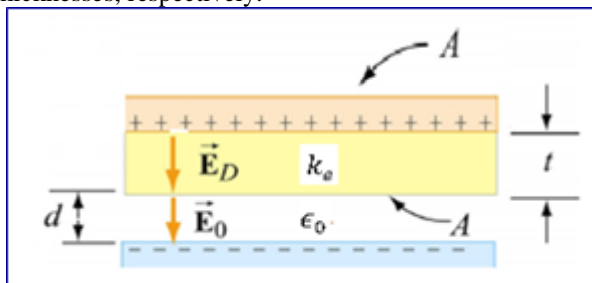

Fig. 7. Cross section parallel plates ozone generator

The potential difference between the two electrodes can be formulated as [15]:

$$V = - \int_+^- E dl = -E_0 d - E_D t = -\frac{Q}{\epsilon_0 A} d - \frac{Q}{\epsilon_0 k_e A} t \quad (14)$$

E_0 & E_D are the electric field values through the ionization gap and the dielectric layer, respectively. A is the electrode surface area and Q is the quantity of electric charges on each electrode.

$$C = \frac{Q}{|V|} = \frac{1}{\frac{d}{\epsilon_0 A} + \frac{t}{\epsilon_0 k_e A}} = \frac{1}{\frac{1}{C_g} + \frac{1}{C_d}} \quad (15)$$

Thus,

$$C_g = \frac{\epsilon_0 A}{d}, \quad C_d = \frac{\epsilon_0 k_e A}{t} \quad (16)$$

C_g & C_d are the capacitances of the ionization gap and the dielectric layer, respectively, whilst C represents the total capacitance.

For ozone generator with electrode surface area of 0.045 m^2 , dielectric thickness of 1 mm , ionization gap thickness of 3 mm , and silica dielectric relative permittivity of 8 [8]; the resulting gap capacitance $C_g = 132 \text{ pF}$ and the dielectric capacitance $C_d = 3.186 \text{ nF}$.

The previous procedure will be applied for co-core cylindrical ozone reactor. Fig. 8 demonstrates co-core cylindrical ozone generator where a is the inner cylindrical radius, b is the dielectric radius, whilst c denotes the outer cylindrical radius.

$$V = - \int_a^c E dr = -\frac{Q \ln(\frac{b}{a})}{2\pi\epsilon_0 k_e L} - \frac{Q \ln(\frac{c}{b})}{2\pi\epsilon_0 L} \quad (17)$$

$$C = \frac{Q}{|V|} = \frac{1}{\frac{\ln(\frac{b}{a})}{2\pi\epsilon_0 k_e L} + \frac{\ln(\frac{c}{b})}{2\pi\epsilon_0 L}} = \frac{1}{\frac{1}{C_d} + \frac{1}{C_g}} \quad (18)$$

Thus,

$$C_g = \frac{2\pi\epsilon_0 L}{\ln(\frac{c}{b})}, \quad C_d = \frac{2\pi\epsilon_0 k_e L}{\ln(\frac{b}{a})} \quad (19)$$

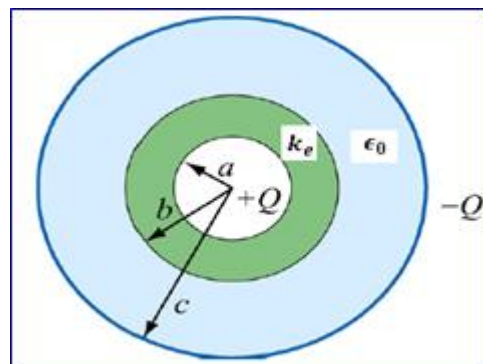

Fig. 8. Cross section of co-core cylindrical ozone generator

4. Conclusion

In this paper, determination topologies of ozone generator parameters have been studied. Lissajous plot achieved good results in frequency range (15-20 KHz). This belongs to the plotting shape which will be distorted outside this range. As a result of this distortion, uncertainty will be occurred in determination of I_0 and Q_0 values. Differential evolution (DE) method, on the other hand, depends on the resonance frequency. This means that as the resonance frequency increases, accuracy of parameter values will be enhanced. A new theoretical methodology is proposed. It is concerned with calculations of the initiation or threshold voltage, dielectric and gap capacitances for parallel and co-axial ozone reactors.

CONFLICT OF INTEREST

The authors declare no conflict of interest.

AUTHOR CONTRIBUTIONS

Mohamed B. El_Mashede suggested the paper title and presented the conclusion after his final revision of the research; Magdy M. Zaky and M. EL_Hanash presented and wrote sections (II and III); A. A. Saleh wrote the introduction; all authors had approved the final version.

References

- [1] L. Dascalescu, "An Introduction to Ionized Gases, Theory and Applications", *Toyoashi University of Technology*, 1993.
- [2] M. A. Dimitriou, "Design Guidance Manual for Ozone Systems", *International Ozone Association (IOA). Pan American Committee*. 1990.
- [3] J.M. Alonso, M. Valdk!, A.J Callej& J. Rivas, J. Lolada, "High Frequency Testing and Modeling of Silent

- Discharge Ozone Generators”, *International Ozone Association*, Vol. 25, pp 363—376. 2003.
- [4] Nacera Hammadi, Mansour Zegrar, Said nemmich, Zouaoui Dey, Sidi-Mohamed Remaoun, Bouregba Naouel, Amar Tilmatine, “Development of High-Voltage high frequency power supply for ozone generation”, *Journal of Engineering Science and Technology*, Vol. 11, No. 5, PP. 755 – 767. 2016.
- [5] Gede Wiratma Jaya et al., “ Characteristics of Dielectric Barrier Discharge (DBD) As an Ozone Generator Reactor”, *OISAA Journal of Indonesia Emas* Vol. 01, No. 01 2018
- [6] Meng Li et al., “Experimental study on ozone generation from oxygen in double surface dielectric barrier discharge”, *Vacuum* (2018).
- [7] Ju Li et al., “A Review of Recent Advances of Dielectric Barrier Discharge Plasma in Catalysis”, *Nanomaterials* 2019, 9, 1428.
- [8] Mario Ponce, “Linear and non linear models for ozone generators considering electrodes losses”, *35th Annual IEEE Power Electronics Specialists Conference*, 2004.
- [9] Olivares, V.H., Ponce-Silva, M., Osorio, R., Juarez, M. (2007), “DBD modeling as a function of waveforms slope”, *Power Electronics Specialists Conference*, 17-21. *IEEE*, 1417-1422. June 2007.
- [10] Koudriamev O., Wang S., N&aoka M., “Advanced Development of Voltage Source Sofi-Switching High-Frequency Invener for Silent Discharge Tube .Loads”, *The Third International Power Electronics and Motion Control Conference*. 2000. Proceedings PIEMC 2000.. Vol. I, pp 302-307, Aug. 2000.
- [11] Muhammad Amjad, Zainal Salam, Mochammad Facta, and Kashif Ishaque, “A Simple and Effective Method to Estimate the Model Parameters of Dielectric Barrier Discharge Ozone Chamber” *IEEE Transactions on Instrumentation and Measurement*, Vol. 61, NO. 6, JUNE 2012.
- [12] Siseerot Ketkaew, “The Case Study of 5 kHz – 25 kHz High Frequency Adjustment in Converter Circuit to Generate Ozone Gas”, *AU J.T.* 11(1): 42-47. Jul. 2007.
- [13] Zainal Salam ; Mochammad Facta ; Muhammad Amjad ; Zolkafle Buntat, “Design and implementation of a low cost, high yield dielectric barrier discharge ozone generator based on the single switch resonant converter”, *IET Power Electronics*, Vol. 6, Iss. 8, PP. 1583-1591 ,September 2013.
- [14] M. Amjad, Z. Salam, K. Ishaqu, “A Model Parameter Extraction Method for Dielectric Barrier Discharge Ozone Chamber using Differential Evolution”, *Measurement Science Review*, Volume 14, No. 2, 2014.
- [15] Bo Thide’, “*Electromagnetic Field Theory*”, *Swedish Institute of Space Physics Uppsala, Sweden and Department of Physics and Astronomy Uppsala University*, Sweden, 2009.

Creative Commons Attribution License 4.0 (Attribution 4.0 International, CC BY 4.0)

This article is published under the terms of the Creative Commons Attribution License 4.0

https://creativecommons.org/licenses/by/4.0/deed.en_US