

A Reusable and Interoperable Semantic Classification Tool Which Integrates Owl Ontology

SAADIA LGARCH¹, MOHAMMED KHALIDI IDRISSE² AND SAMIR BENNANI³

^{1, 2, 3} Mohammadia Engineering School,
Mohamed V - Agdal University
Avenue Ibsina B.P. 765 Rabat
Morocco

¹saadiagm@gmail.com, ²khalidi@emi.ac.ma, ³sbennani@emi.ac.ma

Abstract: - In e-Learning systems, tutor plays a very important role to support learners, and guarantee a learning of quality. A successful collaboration between learners and their tutor requires the use of communication tools. Thanks to their flexibility in terms of time, the asynchronous tools as discussion forum are the most used. However this type of tools generates a great mass of messages making tutoring an operation complex to manage, hence the need of a classification tool of messages.

We proposed in a first step a semantics classification tool, which is based on the LSA and thesaurus. The possibility that ontology provides to overcome the limitations of the thesaurus encouraged us to use it to control our vocabulary.

By the way of our proposed selection algorithm, the OWL ontology is queried to generate new terms which are used to build the LSA matrix. The integration of formal OWL ontology provides a highly relevant semantic classification of messages, and the reuse by other applications of ontological knowledge base is also guaranteed. The interoperability and the knowledge exchange between systems are also ensured by ontology integrated.

In order to ensure its reuse and interoperability with systems which requesting for its service of classification, the implementation of our semantic classifier tool basing on the SOA is adopted and it will be explained and tested in this work.

Key-Words: - E-learning, tutoring, ontology, discussion forum, semantic classification, SOA, reuse, interoperability, web service, orchestration

1 Introduction

The success of any work performed by several actors who have to work together to achieve a common goal, depends on the collaboration tools available to them. When the work to successfully complete is distance learning, success becomes a challenge in front all interveners in this work. There where collaborative learning is organized according to both synchronous and asynchronous interactions between learners and their tutor, has shown its advantages in the success of online learning.

The sense of isolation that the learner feels constitutes an important factor among several which generate his abandonment in distance learning. To make learners free from this feeling which presents the main cause of all abandonments in Distance learning, the tutor is called then to play a very important role to ensure a best unrolling of the

distance learning process and giving good support to learners to help them feel more motivated to learn more effectively.

The tutor plays the role of facilitator who helps learners to choose their project, facilitating their expression. He is also a moderator who synthesizes, criticizes and structures the content, while managing and reinforcing the deadlines for completion of activities. In addition to the tutor can also play the role of an expert who helps learners to find documents and resources while providing them his personal experience, without forgetting his emotional support. All this shows the importance of mentoring in a distance learning system, and the need to use communication tools becomes essential. The asynchronous communication tools, particularly discussion forums allow the exchange of information in flexible way. But in return they

generate a great mass of messages. We thus see that the volume of messages exchanged generates noise, proportional to the number of interveners. This makes the exploitation of this mass a heavy and impractical. The undesirable mixture of messages from different contexts and different objectives generates a block and slowness in reply's time. A member of a working group that is remote requires functionalities to be included in the asynchronous communication tools to facilitate to him the task of researching the desired information in a very fast way and depending on the intended context.

To help a user who can be a tutor or an instructor to find a message posted in a discussion forum, most classification methods provides a search based on keyword. The research results are dependent and proportional to the appropriateness of terms used for search.

We presented in [8] an approach to manage this mass of messages, by a classification of messages according to their semantic context; this classification is based on the method LSA (Latent Semantic Analysis). We have also proposed the construction of a thesaurus that will bring to the messages posted by learners, a semantic context. The results thus found by using a thesaurus seem satisfactory [8]. However it is necessary to signalize some insufficiencies in using the thesaurus.

The thesaurus is characterized by a degree of semantic precision given for the presentation of knowledge that limits its use for automatic indexing. The thesaurus also lacks a conceptual level of abstraction. The thesaurus provides also vague and ambiguous relations between terms, and may contain conflicting information.

In this context of distance learning we focus on the reuse of knowledge, something that the thesaurus can not satisfy. We conducted then an investigation on the side of the ontology. This last allows reuse by creating and maintaining reusable knowledge. The ontology allows also the assembly of knowledge bases from reusable modules. The sharing of knowledge and communication is also possible with ontologies since they provide interoperability between systems and enable the exchange of knowledge between these systems [37].

The ontology can thus overcome the insufficiencies of the thesaurus through the opportunity to represent the knowledge of a domain by identifying and modeling concepts and conceptual relations. The ontology can also formalize the conceptualization and corresponding vocabulary, this formalization which also targets to remove any ambiguity [38].

All these qualities that ontology possesses render its degree of semantic precision for the presentation of

knowledge higher. We then propose to adapt our classifier to ontology instead of a thesaurus.

To query the OWL ontology, we proposed in [10] a selection algorithm that finds the terms semantically closest to those introduced by the user via the OWL ontology. The set of new generated terms presents the key element which leads to the construction of the LSA matrix. The LSA method is then applied to the LSA matrix whose rows represent all the new terms generated, while the columns represent all discussion forum messages. The implementation of the selection algorithm is mainly based on the SPARQL Query Language.

The founding principle of our semantic classifier is to assist the tutor in a device of E-Learning; it must firstly be interoperable with platforms for distance learning soliciting its classification service. Secondly, the classifier should be reusable with a high degree of granularity, respecting web standards. To satisfy the properties mentioned above, we proposed in [45] to adopt SOA to our semantic classifier, by decomposing it into web services around which new computing standards are emerging, where the ease of architectural approach of service-oriented type [24].

Reuse and interoperability of components and services takes a very important part among the objectives traced by our research team RIME (Computer Networks, Modeling and E-Learning or "Réseaux Informatiques Modélisation et E-Learning" in french). Develop an open platform for integration, development and management of distributed software components is the targeted objective. Since our work is part of the overall project of our team, so it should follow the lines traced by this latter. The convergence of the majority of new applications to reuse and interoperability, encouraged us to make our classifier reusable in its entirety without restrict ourselves only to its knowledge base.

For this, we proposed to adapt a service-oriented architecture to our classification tool by identifying two web services which represent a high degree of granularity for our classifier tool [11]. This architecture was improved and implemented in [45], while adopting the notion of orchestration for composing our services, and converging towards a composite application that follows the concept of service-oriented architecture, and that respects the web standards: HTTP, XML, SOAP, WSDL, UDDI and BPEL. The respect of web standards will make our tool reusable with a large granularity through these composite services, while enabling its interoperability with applications that solicit its classification service.

The purpose of this paper is to test the semantic classifier tool in its new SOA architecture, and see the impact of this architecture on the semantic classification quality, highlight the collected gains in terms of reuse and interoperability.

We will adopt the following plan. In the first section we describe the principal aspects of collaboration in distance learning, and in particular the collaboration between tutor and learners in e-learning. The asynchronous tools are also cited in this section while citing the problem generated by this type of collaboration tools. In section 3, we describe, the essential elements on which is based the semantic classification tool presented in [8] and which is based on the integration of a thesaurus and the application of the LSA method. The insufficiencies identified in the use of the thesaurus are also presented in the third section. The fourth section is dedicated to explain the functionalities of the new semantic classifier tool using OWL ontology. The importance of reuse and interoperability are defined in the section 5. The importance of making Our classifier reusable and interoperable in its entirety without restricting ourselves to its knowledge is also presented in the fifth section while representing the SOA architecture on which our classifier is based. Section six is dedicated to the implementation of a prototype of our semantic classifier in its SOA architecture. Testing the classifier tool is also presented in the section six. At the end we give a conclusion and prospects for our next works.

2 Collaboration between tutor and learners in a system of E-Learning

In an environment of E-Learning, the tutor presents a principal actor, who allows the bearing of several problems that learners encounter in their learning pathway. Among these problems, we cite the problem of isolation felt by the learner and which presents a real obstacle in the continuity of their learning. The tutor is called to collaborate with learners by providing the necessary support during their learning.

to make successful the collaborative working group of this type and whose members are geographically and temporally law, and that are called work together to achieve a common task remains a challenge in front all participants in this work, and in particular in front the tutor. To succeed this challenge, the use of collaboration tools is required. Among the collaborative tools that can help the tutor in his work tutoring, we find the coordination tools and the communication tools. In this work we are

particularly interested in communication tools and in particular asynchronous communication tools.

Asynchronous communication tools, allow an exchange of information with a very flexible way. This mode of asynchronous communication, promotes supervision of learners on the pedagogical, technical and socio-emotional terms.

2.1 The online distance learning (E-Learning)

The DL (Distance Learning), ODL (Open Distance Learning) and E-Learning [2] are terms often used to describe new ways of learning and to make learn, while trying to reduce geographical and temporal constraints of participants [1]. Behind these words, different terminologies are used according to the authors who employ them [2].

Based on computer networks (Internet, Intranet and Extranet) as support for the dissemination of learning, for interaction and communication between interveners in online learning , the e-Learning presents an evolved form of distance learning [1] [3]. This type of learning includes the distance teaching in distributed environment (other than the classical correspondence teaching). In E-Learning the access to resources is done by downloading or by consulting them on the Internet. The E-Learning type of formation, may involve the synchronous or asynchronous mode, with tutoring systems, systems based on self-study or a combination of these elements [2].

In addition to the fact that it responds to geographical constraints, the E-Learning is also intended to feed the distance learning with a variety of methods privileging a learning process to bring the knowledge of the formed [1].

The E-Learning is thus characterized by its efficiency to meet an important set of learning needs, while expanding access to resources and opportunities for collaboration and interactivity [1]. View of its importance and to possibilities offered by E-Learning, we are interested in this type of learning, thanks to the various advantages proposed. In this work, we are particularly interested in collaboration in the distance learning of type E-Learning, and in particular the collaboration between the tutor and the learner.

2.2 Collaboration in a platform of E-Learning

The majority of works that focus on collaborative learning show that individuals who participate in a working group, learn better than an individual who

working alone, and they get better performance than those obtained by an individual who is isolated [1].

Collaborative learning constitutes then a learning strategy where a small group of learners work toward achieving a common goal. In this type of learning, all members of the group working together to achieve the traced goal, without any repetition of tasks. It's the result of a spontaneous and voluntary participation of group members, which appeals to autonomy while combining processes of individual and collective work [1].

Several authors as Dillenbourg [4], consider that collaborative learning may offer interactions richer and more intense between members of the group. Interactions elicited by this form of learning are defined by how they influence the cognitive process (process that considers the learner able to receive, treat and filter information derived from the world of outside) of each individual group. During the collaboration, the interactions are also characterized by the negotiation that they release between the peers, and so none of the peers will impose her point of views based on his authority, but on the contrary a justification and an explanation are needed to convince others while negotiating with them [1].

Collaborative learning can take several forms: between learners (learning group), between learner and tutor and between tutors (coordination).

In our research, we are interested in collaborative learning between tutor and learner. We are in particular interested to role that may be played by tutor in a platform of E-Learning to help the learner in his distance learning cycle (tutoring).

2.3 The importance of the tutoring side in a system of e-learning

Among Important factors that generate the abandonment of the learner in distance learning, we find the sense of isolation felt by learner [5]. To make learners free from this feeling which presents the main cause of all abandonments in distance learning, the tutor is called then to play a very important role to ensure a best unrolling of the distance learning process and giving good support to learners to help them feel more motivated to learn more effectively [6].

The presence of a tutor in distance learning, is essential and its absence can generate many difficulties for the learner when he is little autonomous, and in this case the tutor's presence may facilitate the independent and collaborative learners [7]. The need to improve progressively the existing tutoring systems is consistent, and this by integrating more features which assure a better collaboration (tutor learner side).

2.2.1 The tutoring side in a system of E-learning

According to the Dictionary of Education Legendre (1993, p. 1378), "The tutor is a guide, an instructor who teaches a single person or a small group of students both; he is an advisor to students" [12].

The presence of tutoring in E-learning system is essential, so its absence can cause many difficulties for the learner, when he is not autonomous. The presence thus of a tutor can facilitate collaboration and autonomy of learners [7].

The tutor is led to play a very important role for ensuring a better development process for distance learning, while giving good support to learners. He helps them to feel more motivated to learn better, while freeing themselves from the feeling of isolation which constitutes the main cause of the totalities of abandonments of learners in distance education [5]. The need to improve progressively the existing tutoring systems is consistent, and this by integrating more functionalities that enable greater collaboration (learner tutor side).

In an E-learning formation, tutor plays a major role in the learning cycle of learners. Specifically, the tutor helps learners to assimilate the courses that are presented on the platform of E-learning.

According to Bernadette Charlier and her colleagues [9]; for the success of learning, the tutor must be identified, and his interventions can thus be defined according to four complementary roles. The tutor can then play the role of facilitator who helps learners to choose their project, facilitates their expression, listens to other learners, and takes into account the views of their peers. Moderation is one of the roles that the tutor can also play, and this by synthesizing and criticizing, structuring the content, and managing and reinforcing the completion times of activities. The expertise is also a quality that must be present in tutor, and this in order to help learners to find documents and resources, and by furnishing them his personal experience. At last, we can say that tutor is responsible to be engaged personally, and encourages learners by offering them an emotional support [9]. Therefore, the tutor who presents a key member of all groups associated with a virtual classroom, and who provides the tutoring, consists in facilitate the achievement of the goal as efficiently as possible. To overcome the constraints of distance, the activity of knowledge construction which links the tutor at learners must be supported by computer [13].

To collaborate with learners, the tutor has a set of communication and collaboration tools that apply to distance education according to the time parameter. Those communication and collaboration tools can be part of two families. The first family is the

synchronous tools which require the presence of users at the time of the communication. For their part, asynchronous communication tools don't require time constraints, and thus they offer more freedom for users [6].

2.2.2 The discussion forum: A collaboration asynchronous tool

To achieve its goal, the tutor has a set of communication tools, and the most used are those asynchronous. This is due to their flexibility, because it is not necessary to find the same time slots. Asynchronous tools allow users who share and collaborative work to manage their time according to their availability. On the other hand, learners better structure their knowledges in terms of appropriation / restitution because they take time of reflection [48]. As asynchronous communication tools, we find the e-mail, mailing lists, FAQs and discussion forums, etc.....

Being an asynchronous communication tool, the discussion forum allows to remotely assembling discussion groups and make possible all the time the communication between participants. It also mediates the exchange and keeps the track. All messages exchanged during a discussion are stored and can be read and reread by all who have access [6]. The discussion forum allows on one hand, a greater freedom to users, because there is no time constraints during the exchange of messages, where a good flexibility through manipulation.

2.2.3 The need of assistance to better handle the asynchronous communication tools

The asynchronous communication tools such as the discussion forum are too useful and especially for tutoring. But in parallel, the tutor in his corner finds a lot of difficulties to managing the mass of messages he receives, and for which he must respond as soon as possible. Messages received by tutors are characterized by the ambiguity of their context, in addition, the importance of a message by another is not reported, hence a need felt by the tutor requiring classification and organization tools to facilitate searching and access to information with the simpler manner [6].

Generally, the accompaniment of the tutor for the learner with better collaboration requires a mechanism for filtering semantics of messages from the base where they are stored.

To help a user who can be a tutor or a supervisor to find a message posted in a discussion forum, the majority of classification methods propose a search based on keywords. The research results remain dependent and proportional to the relevance of the

words used to search. We presented in [8] an approach to manage this mass of messages, making a classification of messages based on their semantic context; this classification method is based on the LSA (Latent Semantic Analysis). We also proposed the construction of a thesaurus that will provide to messages posted by the learners a semantic context.

3 The semantic classifier tool integrating a thesaurus

The classification tool introduced in [8] is based on LSA (Latent Semantic Analysis) with a reinforcement of the classification by integrating a thesaurus.

Based on the singular value decomposition (SVD), the LSA method allows to find similarities between the documents (texts, sentences, words) [35] [6].

In order to have relevant results we have proposed to widen the scope of research while respecting the context requested. The use of the technologies proposed by the Semantic Web in particular those that enable the organization of vocabularies in a semantic way, was necessary. For this, we first chose the thesaurus.

3.1 Semantic Web

The term Semantic Web attributed to Tim Berners-Lee [34] denotes a set of technologies to make the content of resources on the World Wide Web accessible and usable by software agents and programs, through a system of formal metadata, including using the family of languages developed by W3C.

The Semantic Web does not call into question the classic web, because it is based on it, especially a means of publication and consultation documents. The automatic processing of documents via the semantic web is done by adding formalized information (markers) that describe their content and their functionalities instead of texts written in natural languages (French, Spanish, Chinese, etc..) [32]. Moreover, for the manipulation of semantic markers, we need semantic resources that help to define a vocabulary for such markers and also allow concepts sharing and interoperability. Among these resources we find the taxonomies, semantic networks, thesaurus and ontologies [8].

3.2 Thesaurus

The international standard ISO 2788 (1986) defined the thesaurus as the « vocabulary of a controlled indexing language formally organized in order to explicit the relationship priori between notions (eg relationship generic / specific) ». According to the

same standard, an indexing language is a « set of controlled terms and selected from a natural language and used to represent in condensed form, the contents of documents ».

The thesaurus was designed in the late 1950s. Its first function was to overcome the disadvantages of natural language: by grouping different meanings in the same form meaningful and dispersion of information in terms more or less similar semantically. The thesaurus is as an instrument of control and structuring of the vocabulary; it contributes to the consistency of indexing and facilitates information retrieval [43].

The terms in a thesaurus are conceptually organized and interconnected by semantic relations. These relations are of three types: hierarchical, equivalence and association [8].

The possibility that the thesaurus gives in terms of semantic classification of terms of a given vocabulary, we have encouraged on one hand to integrate it as an essential component in the classification presented in [8]. On the other hand, the simplicity of relations and of terms that the thesaurus presents, has facilitated the implementation of the classifier and to see the first results when a semantic resource of organization of words is integrated.

3.3 Proposed approach based on the Thesaurus and LSA

To help a user find a message posted to a discussion forum, most methods of classification provides a research based on keywords. The research results obtained are dependent and proportional to the relevance of keywords chosen by the user [8].

We presented in [8] a tool for classifying the messages of a discussion forum that is based on a semantic approach. This approach allows managing the mass of messages accumulated with applying a classification according to their semantic context. The classification made is based primarily on the LSA method. In order to increase the performance of the method chosen by extending the terms used in the construction of Table lexical (words / documents) and thus improve the classification, we thought to organize these terms with other terms in a hierarchical manner using a thesaurus.

Our implementation was done in three stages. In the first one, we only implemented the LSA. The integration of the thesaurus as a resource semantics has been the subject of two approaches. The first approach is to include more keywords specified by the user, the specific terms that are associated through the thesaurus, avoiding repetitions [8].

This approach demonstrates that the results generated are more interesting in terms of semantics as those generated by the LSA method only, because messages of semantics close to that desired are generated without these messages contain the specified keywords. But messages of different semantics are also returned, since they contain terms that are linked to a few key words only and not all of these keywords [6]

To overcome the problem of side messages, an improvement to semantic approach of classification is made [8]. In this case and to build the lexical table, we include in addition to the keywords specified by the user, specific terms defined by the thesaurus, common to those (figure 1):

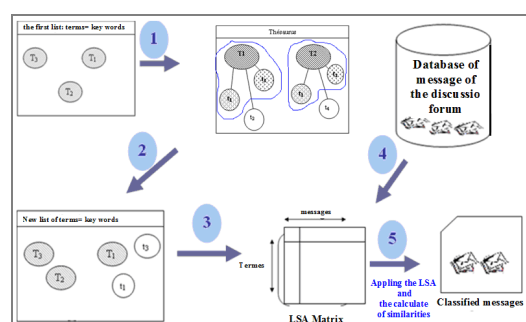

Fig.1. Lexical table include only the common terms

The Improvement made to our basic approach leads to more relevant results than those generated from the first approach. The messages returned are only in the same desired context.

The improved semantic approach allows classifying messages according to a set of terms that belong to the desired themes, based on semantic relations that exist between these terms. The terms used so to enable this classification, are ranked according semantic relations using a thesaurus. The latter is constructed from a corpus of messages of different topics. The application of this approach on a corpus of messages posted through a forum discussion, showed results relevant and rich in semantics, which approves the use of thesaurus prior to the LSA.

The results thus found by using a thesaurus seem satisfactory. However it is necessary to highlight some insufficiencies in the use of thesaurus [13].

3.4 Insufficiencies of Thesaurus

The thesaurus has been created to assist archivists in their task of indexing and queries formulation [39]. The thesaurus is characterized by a degree of semantic precision given for the presentation of knowledge that limits its use for automatic indexing.

This is explained partly because a terminology dictionary, incarnates a representation of a domain (a lexicalization of a conceptualization), which is not as complete as the formal semantics provided by the conceptual representation, and its modest structure, is therefore unsuitable for advanced semantic applications. On the other hand, and in particular, relations linking terms (controlled vocabulary to represent concepts) in a thesaurus (BT, NT, RT) are generally not sufficient for a profound analysis of the semantics of indexed documents [33].

The thesaurus also lacks a conceptual level of abstraction. These are collections of terms that are organized under a single hierarchy or multiple hierarchies but with basic relations between terms. The distinction between a concept and its lexicalization is not clearly established. The thesaurus does not reflect how the world can be understood in terms of meaning. In addition, coverage semantic thesaurus is limited. The concepts are generally not differentiated from their abstract type (such as substances, processes). The relations between terms are vague and ambiguous. The relation "is related to" is often difficult to exploit because it connects the terms by implying different types of semantic relations. It is often difficult to determine the properties of relations "more specific", «more generic» which can combine the relations «is an instance of» or «is part of». The thesaurus also lack consistency and may contain conflicting information [39].

The gains made by reuse, are many. It was perceived for a long time as a means to improve quality and reduce costs and delays in production. Yet like in other areas, reuse in e-learning has become a discipline and focus of research in its own right [40]. In this context, we are interesting to the reuse of knowledge bases, something that a thesaurus can not satisfy.

We conducted then an investigation on the side of the ontology. This last allows reuse by creating and maintaining reusable knowledge. The ontology allows also the assembly of knowledge bases from reusable modules. The sharing of knowledge and communication is also possible with ontologies since they provide interoperability between systems and enable the exchange of knowledge between these systems [37].

The ontology can thus overcome the insufficiencies of the thesaurus through the opportunity to represent the knowledge of a domain by identifying and modelling concepts and conceptual relations. The ontology can also formalize the conceptualization

and corresponding vocabulary, this formalization which also targets to remove any ambiguity [38].

All these qualities that ontology possesses render its degree of semantic precision for the presentation of knowledge higher. We then propose to adapt our classifier to ontology instead of a thesaurus.

3.5 Ontology

Ontology is an explicit specification of a conceptualization of a domain, formed by concepts and relations that allow humans and machines have everything they need to understand and reason about an area of interest or a portion of the universe [14]. On one hand, ontologies allow to describe the knowledge of a specific area, and on the other hand to represent complex relations between concepts, axioms and rules [44]. Ontologies have become a central component in many applications, and they are called to play a key role in building the future "Semantic Web" [36].

A thesaurus or even a taxonomy are forms of ontology whose grammar has not been formalized. When we establish a category and a hierarchy of this categorization, we establish dependencies between these terms. These hierarchies are meaningful outside the vocabulary itself. For example, when we say «this term is a subcategory of that other term», we come giving sense of this relation, we draw a "arrow" between the two by qualifying the arrow and asserting what kind of relation that meant. Ontology corresponds therefore to a controlled and organized vocabulary, and to explicit formalization of relations established between the different vocabulary terms. To realize this formalization, we can use a particular language. Among the languages used to describe the relations between various terms of vocabulary, there are RDF (S) and OWL [15]. All the benefits listed above and relating to ontologies encouraged us to propose a future work using ontology instead of a thesaurus for controlling our vocabulary.

4 Reinforcing the semantic classifier tool using ontology

The possibility that ontology provides to overcome the limitations of the thesaurus encouraged us to use it to control our vocabulary [41]. We then proposed to formalize the ontology using OWL language (Web Ontology Language) [42]. This formalization will allow the querying of ontology during the stage of searching of terms which are semantically related with those explained by the user (tutor).

To reinforcing the classification of our tool in integrating the semantic aspect to it and thus get

better results, we have used some technologies provided by the Semantic Web in particular a formal OWL ontology.

Ontology corresponds therefore to a controlled and organized vocabulary, and to explicit formalization of relations established between the different vocabulary terms. The formalization can be done using the RDF (S) and OWL [15]. Based on the syntax of RDF / XML, OWL takes advantage of the universality of XML syntax and provides the ability to write web ontologies. In addition to the possibilities offered by the ontology to the user by giving him the opportunity to describe the properties and classes, OWL provides tools for comparing the properties and classes. With a broad vocabulary and a real semantic formalism, OWL provides to machines a great capacity to interpret web content offered by RDF and RDFS [15].

All these qualities in favor of formal ontology OWL, were encouraged us to use it to formalize our ontology.

To query the OWL ontology we chose the SPARQL language, because it has the necessary capabilities for querying and optional graph patterns with their conjunctions and disjunctions. According to Tim Berners-Lee, the director of the W3C "Trying to use the Semantic Web without SPARQL, is equivalent to running a relational database without SQL". The conception of SPARQL was in order to be used across the web and thus enables queries over distributed data sources, regardless of format. Creating a query with SPARQL become easier, at lower costs and richer and precise results. The results of SPARQL queries can be sets of results or RDF graphs [47].

The use of a selection algorithm of new terms by querying the OWL ontology [10] presents a key element of our semantic classifier.

The architecture proposed in [10] can be summarized according to the diagram of Figure 2:

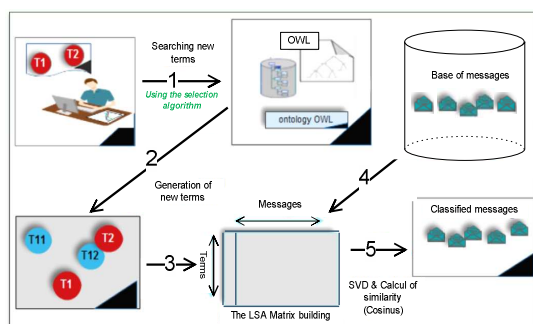

Fig.2.The classical architecture of the semantic classification tool based on OWL ontology

The prototype of system developed and presented in [10] allows the classification of messages according to a set of terms that belong to the desired theme, based on semantic relationships between terms such as relationship of hierarchy and the relationship of association described with the OWL formalism, by "SubClass / SuperClass" and "ObjectProperty" respectively. The classification of message is based on the querying of a formal OWL ontology, which uses an algorithm of selection of terms semantically closest to those introduced by the user. The proposed algorithm [10] is mainly based on the SPARQL language that has all the capabilities needed to query OWL ontology with high accuracy. The tests done in [10] approve the importance of integrating a formal ontology, thanks to these benefits versus a thesaurus. The relevance of the selection algorithm has targeted terms that are closer to those contained in the user query. Thus we see that this algorithm has improved the semantics of message classification.

In addition to the significant benefits that ontology proposes in general [13], and the benefits in particular of a formal ontology, the ontology guarantees also the property of reuse, making possible the reuse of the ontological knowledge base by other applications. The ontology ensures also interoperability between systems and allows the exchange of knowledge between these systems.

The architecture, on which our classification tool is based, shows that the OWL ontology is the only reusable and interoperable part of our classifier tool (Figure 1). To make our classifier reusable in its entirety without restricting ourselves to its knowledge base, we have proposed in [11], a service-oriented architecture (SOA). This type of architecture should satisfy most of the tool's reuse, its interoperability in relation to platforms which solicit its service of classification.

5 The importance of interoperability and reuse

Among quality factors in E-learning platforms, we found that interoperability is a quality factor more and more requested by users, because it represents a critical functionality in open environments like the Web. The satisfaction of the property of interoperability is necessary, because it guarantees a better usability and greater reuse [16]. Interoperability has become a necessity to meet the needs of information exchange between heterogeneous information systems; it reflects the ability of an information system to collaborate with other systems with very different natures some

times [17]. Among the objectives defined by our research team, we find that the reuse and interoperability of component and service has a large important part. Developing an open platform for the integration, development and management of distributed software components is the targeted objective. In this perspective we aim to make our classifier tool reusable by any platform of E-learning, while guaranteeing its interoperability with those systems.

5.1 Reuse

Reuse is defined as the means for the reuse of content and components for different purposes, in different applications, in different products, in different contexts and by different modes of access [16]. It's like the concept of taking something that has already been designed and developed for one purpose and using it for a similar or another purpose [46]. Reuse is a topic that is not new to the science and engineering realms [46].

5.2 Interoperability

The concept of interoperability has not a single definition. Interoperability is generally defined as the ability of a system to interact with another. Interoperability is also defined as the ability to communicate with a system and to access to the functionalities of this system. From engineering point of view, we defined this concept by the ability of two programs to work together without any particular interfacing effort [18]. According to the IEEE Standard Computer Dictionary, interoperability is defined by: "Ability for two (or more) systems or components to exchange information and to use the information that has been exchanged" [19]. Cyrille Simard in his turn has defined interoperability as the means which allows the use of content and components developed by an organization on a given platform by other organizations on other platforms [20]. For Said Kadri [17]; we can say that two systems are interoperable when they have a mutual comprehension of the elements that they share, and when they are able to dynamically discover the different data sources. The exchange of messages and requests must also be possible between two systems so that they are interoperable, while functioning as a single unit for common tasks, and using the functions of each other. We also find that two interoperable systems operate as clients and servers. The property of interoperability between two systems must allow communication even with the internal incompatible components, without

forgetting the approximation of Multi-source queries [17].

5.3 A Service Oriented Architecture toward reuse and interoperability

Implement a service-oriented architecture consist to structure an application, a block of application or a system information to contractualised services which making a functionality while maintaining a service contract. The implementation of global services between application blocks, by entering into a policy of interoperability is the first challenge addressed by the SOA. The second challenge is the search for reuse within an application block or an application, particularly in an infrastructure services or in a business services unit, by entering into a policy of reuse [21].

The SOA also has the advantage of supporting both the distribution and asynchronous mode. In addition, it offers a transparency versus to infrastructures (something indispensable in a context of heterogeneity) [31].

All objectives outlined by the type of service-oriented architecture, has encouraged us to adopt SOA for our classification tool, for ensuring interoperability and reuse of its components. Furthermore, our classifier needs to be integrated into the works of our team which relate to this type of architecture, and in particular, the proposition of an e-Learning Framework that operates on executable models by exposing its functionalities as web services [31].

6 Adaptation of our classification tool to a SOA

The main function of the platforms E-learning is to provide to learners the best activities with the right tools at the right time according to its needs. If an E-Learning is a collection of activities or processes, its functionality can be divided into a number of autonomous functions, which can then be realized separately in form of autonomous applications or e-services, using the technologies of the approach service oriented [22]. This last has found an echo, and that has been used in order to improve or complete features of E-Learning [23].

The founding principle of our semantic classifier is to assist the tutor in a device of E-Learning; it must firstly be interoperable with platforms for distance learning soliciting its classification service. Secondly, the classifier should be reusable with a high degree of granularity, respecting web standards. To satisfy the properties mentioned above, we propose to adopt SOA to our semantic

classifier, by decomposing it into web services around which new computing standards are emerging, where the ease of architectural approach of service-oriented type [24].

6.1 The Service Oriented Architecture

The need for business agility has become imperative. The agility of the information system is satisfied if it is integrated and responsive. To Make dialoguing two different systems in a flexible and easily way is a persistent problem, and an overall integration of type "loosely coupled" is needed [25]. The concept of SOA is a form of mediation architecture, which is an interaction model application, which implements services. These services are on one hand, with high internal consistency with use of a central exchange format, usually XML, and they are in another hand in external couplings as "cowardly", by calling an interoperable layer of interface, usually a web service. SOA is a very effective response to problems faced by companies in terms of reuse and interoperability between different systems that implement their information systems [32].

The main implementation of these concepts and on which the SOA rests, is based on web services [26].

6.2 Web Service

Web service is a computer program which allowing communication and exchange data between heterogeneous applications and systems in distributed environments [32]. The web service interacts with other web services using messages based on XML, and routed by Internet protocols [27]. The architecture of Web services has imposed itself due to its simplicity, readability and its normalized foundations. The web service is a concept based on three essential elements. The first element is the SOAP protocol, which based on XML, and which allows the exchange of information. The second element is the WSDL language, which based on XML, and which allows to describe the service settings. In the end, we find the UDDI element, which represents a distributed architecture, and which allows holding of the description of services [28] [22].

6.3 The composition of web services: Choreography or Orchestration?

The composition of web services specifies which services need to be invoked in what order and how to manage exception conditions. For this, there are

two mechanisms: the choreography and the orchestration [29].

In choreography mechanism web services composition, each web service involved in the process, knows exactly when its operations must be executed, and with which, the interaction should take place. The choreography is based on collaboration, and it's mainly used for exchanging messages at the public business process (figure 2) [30]. The choreography traces then the sequence of messages that may involve several Web Services [29]. In addition, and Contrary to the orchestration, there is no central coordinator [29].

In difference of choreography, the orchestration's principle returns to describe the interaction of services at messages level using the business logic and the order of interactions execution. The orchestration plays on the fact that all the composite web services have no knowledge to be mixed in a composition, and to be part of a business process [29]. In orchestration, the web service invoked is under the control of a central single process (another web service). This core process coordinates the execution of various operations proposed by the web services that participate in the process (Figure 3) [30].

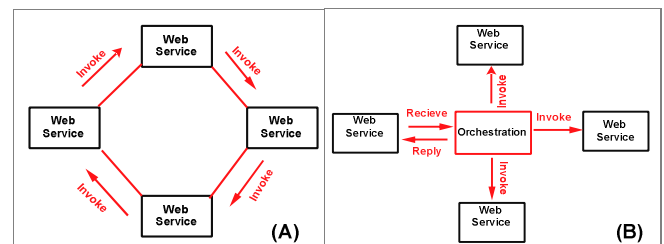

Fig.3. (A) The Choreography composition of web services / (B) The Orchestration composition of web services [30]

The orchestration provides a rapprochement more flexible than the choreography. Its simplicity is due on one hand to the fact that the leader or coordinator of the entire business process is known. On other hand, the orchestration has the potential to incorporate the composite web services without worries and without that they are conscious of belonging to a business process [29] [30].

For our work we chose the concept of orchestration for composing the web services, thanks to the benefits offered by it in comparison with the choreography.

To define the business process, and specify the composite web services, there are several languages. Among these languages we cite BPEL (Business

Process Execution Language), which represents the result of the unification, and the evolution of three different attempts to standardize definitions of business processes: XLANG, WSFL and WSCL. Based on XML, BPEL is the most complete standard that exists for describing business processes. In addition it's the most industrially supported, and the better accepted by developers [29]. It describes the interaction of business processes based on web services, both within and between companies. The companies using BPEL may well define their business processes and ensure interoperability not only on the scale of the enterprise, but also with their Commercial partners within a web services environment. With BPEL it's possible to make interoperability between commercial activities, which are based on different technologies [29].

Thanks to the set of advantages cited above, we opted for the standard BPEL for composing the web services of our semantic classification tool.

6.4 The architecture oriented services adopted for our classifier tool

We presented in [45] the granulation of the semantic classifier in the form of web services, following the SOA architecture (Figure 4).

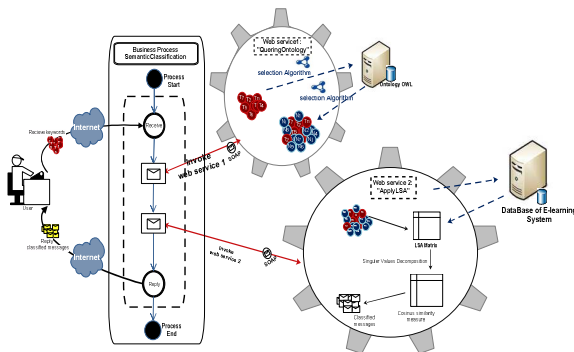

Fig.4.The SOA adopted for our classifier tool

The user launches his request for classifying messages of the forum discussion by introducing a set of keywords. This set of keywords is well received by the business process "SemanticClassification", which in its turn invokes the first Web service "QueryingOntology". The "QueryingOntology" service takes care of querying the ontology, based on the algorithm of selection of new terms already proposed in [10], and using the Ontology's URI. The set of new terms found, will be then returned to the business processes, that in turn invokes the second Web service Web "ApplyLSA" by communicating this set of new

terms. Based on messages from the database of the discussion forum, and all new terms generated via the ontology, the web service "ApplyLSA" built then the LSA matrix. The "ApplyLSA" service applies then the singular value decomposition to the LSA matrix, and obtains the SVD matrix, and passes to the calculation of similarities between the columns of this last matrix. On receipt of the response of web service "ApplyLSA", the business process responds the user by sending to him a message "reply" that envelops the set of messages that follow his desired theme.

7 Implementation and testing

7.1 Implementation

The implementation of our semantic classification tool means to develop a composite application that is based on the business process "SemanticClassification". The implementation of our BPEL business process is performed using the graphical editor offered by NetBeans (Figure 5). The process "SemanticClassification" communicates with two web services via SOAP messages.

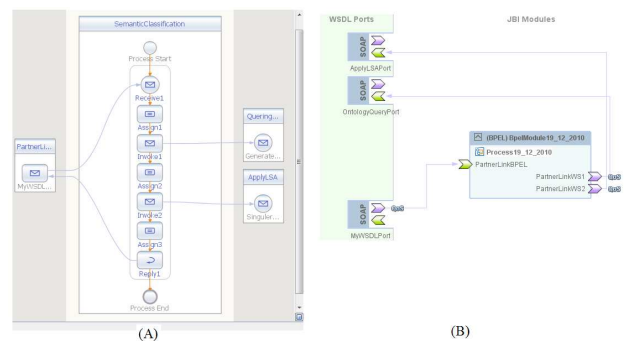

Fig.5. Implementation of business processes "SemanticClassification" (A) / the corresponding composite application (B)

The first web service "QueryingOntology" queries the OWL formal ontology, applying the selection algorithm of terms [10]. This web service is based on tools cited as the Jena API dedicated to the creation of Semantic Web applications, and the manipulation of ontologies. Our web service also calls Pellet, which is an engine designed for reasoning on description logics, and accepting input OWL files. In addition to the two first elements, we also cite the SPARQL query language [10]. The implementation of the second web service "ApplyLSA", calls the "Jama" package, which allows for the singular value decomposition, and the

cosinus similarity measure to calculate similarities [10].

7.2 Tests

To test our classifier in its new SOA architecture, we will introduce the same thematic as introduced in [10]: "Routage dynamique interne". This thematic chosen will then be wrapped in the SOAP request message (Figure 7). Ce message SOAP est ensuite reçu par le service web "QueringOntology" de la part du processus métier.

```
<soapenv:Envelope xsi:schemaLocation="http://schemas.xmlsoap.org/soap/envelope/
http://schemas.xmlsoap.org/soap/envelope/" xmlns:xsi="http://www.w3.org/2001/XMLSchema-
instance" xmlns:xsd="http://www.w3.org/2001/XMLSchema"
xmlns:soapenv="http://schemas.xmlsoap.org/soap/envelope/"
xmlns:myw="http://j2ee.netbeans.org/wsdl/MyWSDL">
<soapenv:Body>
<myw:MyWSDLOperation>
<part1>Routage dynamique interne</part1>
</myw:MyWSDLOperation>
</soapenv:Body>
</soapenv:Envelope>
```



Fig.7. The SOAP request enveloping the theme "Routage dynamique interne"

As a response to this message, the business process receives another SOAP message that envelopes all classified messages according to the chosen thematic (Figure 8):

```
<?xml version="1.0" encoding="UTF-8" ?>
<SOAP-ENV:Envelope xmlns:SOAP-ENV="http://schemas.xmlsoap.org/soap/envelope/"
xmlns:xsd="http://www.w3.org/2001/XMLSchema" xmlns:xsi="http://www.w3.org/2001/XMLSchema-instance"
xsi:schemaLocation="http://schemas.xmlsoap.org/soap/envelope/
http://schemas.xmlsoap.org/soap/envelope/">
<SOAP-ENV:Body>
<m:MyWSDLOperationResponse xmlns:m="http://j2ee.netbeans.org/wsdl/MyWSDL">
<part1 xmlns:m:msgns="http://j2ee.netbeans.org/wsdl/MyWSDL" xmlns="">
<ns1:SingularValueDecompositionResponse xmlns:ns1="http://WS/">
<return>1) le routage dynamique se fait en suivant un protocole de routage comme RIP,
IGRP ,OSPF et d'autres protocoles. chaque protocole suit une logique pour construire la table de
routage du routeur. <br/>-- Sim:0.46656947481584254 </return>
<return>2) qu'elle est la différence entre le protocole de routage RIP et OSPF et lequel est le plus
utilisé dans le monde pour garantir un meilleur routage dynamique? <br/>--
Sim:0.4364357804719845 </return>
<return>3) l'opération de routage consiste à trouver le plus court chemin pour acheminer un
paquet IP ,&nbsp;quel le principe du protocole RIP ? <br/>--
Sim:0.4364357804719844 </return>
<return>4) est ce que c'est pour RIP ou&nbsp;c'est pour OSPF a&nbsp;à chaque instant l'état
global du réseau ? et quel le protocole utilisé au Maroc ? <br/>--
Sim:0.37796447300922725 </return>
.....
<return>11) le principe du protocole RIP est le suivant: RIP est simple et utilise la notion de
vecteur de distance. RIP se base aussi sur la métrique de saut <br/>--
Sim:0.3289758474798841 </return>
<return>12) Quelle est la différence entre EGP et BGP aussi celle qui existe entre RIP et OSPF et
IGRP ? <br/>-- Sim:0.30860669992418427 </return>
<return>13) quels sont les concepts de base sur lequel EIGRP et OSPF reposent ? <br/>--
Sim:0.3086066999241839 </return>
<return>14) Quel est l'intérêt d'OSPF par rapport aux autres protocoles ? <br /><br/>--
Sim:0.3086066999241837 </return>
.....
<return>67) est ce que EGP travaille au niveau d'un système autonome ou à l'extérieur de celui-
ci? et c'est que la différence entre EGP et BGP ? <br/>-- Sim:-1.0 </return>
.....
<return>92) c'est quoi le rôle de EGP et BGP ? <br/>-- Sim:-1.0 </return>
.....
</ns1:SingularValueDecompositionResponse>
</part1>
</m:MyWSDLOperationResponse>
</SOAP-ENV:Body>
</SOAP-ENV:Envelope>
```

Fig.8. The SOAP response enveloping the classified messages

The invocation of web services required is based on the contract or the WSDL file "MyWSDL.wsdl" (Figure 5).

The prototype system developed allows the classification of messages according to a set of terms belonging to the desired thematic, respecting always the objectives traced in [10] for our classifier (all messages which similarity measure verify $sim > 0$ are returned like messages 1, 2, 11 and, 14, but those which similarity measure verify

like messages 67 and 92). The improved of our tool at its architecture, has not diminished the degree of its effectiveness in terms of semantic classification, but instead it saves in terms of reuse and interoperability and that the type of service-oriented architecture guaranteed.

8 Conclusion and prospects

The integration of a formal ontology and relevance of the selection algorithm targeted the terms that are semantically closest to the user query hence a better classification.

In order to ensure its reuse and interoperability with the systems which soliciting its classification service and without being restricted to its ontological basis, the classification tool is implemented following a service-oriented architecture.

With improvements made to the classifier, this last becomes interoperable with platforms that require its service of classification, and this by respecting the web standards (HTTP, XML, SOAP, WSDL, BPEL and UDDI) and which are present in the kernel of an architecture of this type.

The prototype of the system implemented and tested shows the respect to of objectives established for the first time for our classifier. The enhancement made to our classification tool at the level of its architecture, has not diminished the degree of its effectiveness in terms of semantic classification, but instead it allows him providing reuse and interoperability with other systems.

The discussion forum messages are from different databases which may be of various data sources (relational DBMS, object-oriented DBMS, a web page, ... etc.) and of various structures (tables of different structures).

Our classifier is called to access the data sources of different platforms of E-learning while respecting the type of database, its structure and using the corresponding language (SQL, OQL, XQUERY, .. etc..) to access to the desired data with a large transparency.

As perspectives, we propose to find a way ensuring to our classifier the access to data of different platforms regardless of their types or their structures.

References:

[1] D. Bouzidi, « Collaboration dans les cours hypermédia du système de télé- enseignement SMART-Learning », *thèse de doctorat*, Université Mohammed V- Agdal -Ecole Mohammadia d'ingénieurs, 2004.

- [2] C. Roupie, « Tutorat et lien social dans un dispositif de formation hybride », *Master 2 Professionnel (Ingénierie et conseil en formation)*, Université de Rouen, 2008.
- [3] G. Paquette, « Construction de portails d'apprentissage. Explor@ - Une diversité de modèles pédagogiques ». *Sciences et techniques éducatives*, (7), 1, 207-226, 2000
- [4] P. Dillenbourg, M. Baker, A. Blake et C. O'Malley, « The Evolution of Research on Collaborative Learning », In E. Spada & P. Reiman (Eds.), *Learning in Humans and Machine: Towards an interdisciplinary learning science*, Oxford: Elsevier, 189-211, 1995.
- [5] R. Faerber, « Accompagner les apprentissages à distance et collaborer en petits groupes ». *Quatrième congrès AECSE 2001*. Villeneuve d'Ascq, 5, 6, 7 et 8 septembre 2001.
- [6] S. Lgarch, " Une approche sémantique de classification de messages d'un forum de discussion basée sur la méthode LSA", *DESA Report*, Mohammadia School of Engineers (EMI), Mohammed Vth university Agdal, 2008.
- [7] J. Rodet and A. Goll, "Les interventions tutorales facilitant l'autonomie et la collaboration des apprenants à distance", *Theme 5, a proposed formation for Epistema (European leader in distance learning technologies)*, 2010
- [8] S. Lgarch, D. Bouzidi, S. Bennani, « Une approche sémantique de classification de messages d'un forum de discussion basée sur la méthode LSA » *1er Workshop sur les Nouvelles Générations de Réseaux: La Mobilité*, WNGN'08, FST de Fès, 2008.
- [9] B. Charlier, A. Daele, F. Docq, M. Lebrun, S. Lusalusa, R. Peeters, N. Deschryver, " tuteurs en ligne: quels rôles quelle formations", in *Actes du Symposium international du C.N.E.D*, Poitiers, 1999
- [10] S. Lgarch, M. Khalidi Idrissi and S. Bennani (2010). "A selection algorithm of terms from OWL ontology for semantically classify messages". *International Journal of Engineering Science and Technology*, Vol. 2(11), 2010, pp 6788-6800.
- [11] S. Lgarch, M. Khalidi Idrissi and S. Bennani, "Adoption of a SOA to converge towards a reuse and an interoperability of the semantic classifier of messages", in the proceedings of the 4th. *International Conference on Information Systems and Economic*

- Intelligence (SIIE '11), February 2011, Marrakech, Morocco.
- [12] A. Daele, F. Docq, "tuteur en ligne: quelles conditions d'efficacité dans un dispositif d'apprentissage collaboratif à distance ?", in Communication au colloque de l'AIPU, 2002
- [13] S. Lgarch, M. Khalidi Idrissi and S. Bennani, "Adaptation of classification semantic approach of messages of a discussion forum based on the LSA method to ontology", in the 3d International conference on SIIE; Sousse, Tunisia; 18-20, 2010, ISBN. 978-9973-868-24-4, pp. 29-36.
- [14] A. Moujane, D. Chiadmi and L. Benhlime, "Semantic Mediation: An Ontology-Based Architecture Using Metadata", CSIT 2006, Amman, Jordanie, 2006.
- [15] K. Dubost « Ontologie, thésaurus, taxonomie et Web sémantique »
<http://www.la-grange.net/2004/03/19.html>
- [16] S. Laalaj, "Évaluation de l'interopérabilité d'une plate-forme de téléapprentissage". Mémoire de Maîtrise en informatique, University of Quebec, Montreal, 2006.
- [17] S. KADRI, "Interopérabilité des bases de données hétérogènes et réparties". Mémoire de Magister spécialité Informatique, University of Mohamed Boudiaf, M'sila, Faculty of Sciences and Engineering Sciences ,2006.
- [18] J. Le Duigou, " Cadre de modélisation pour les systèmes PLM en entreprise étendue application aux PME mécaniciennes ", doctoral thesis, École Centrale de Nantes, France, 2010.
- [19] A. Geraci, IEEE Standard Computer Dictionary: Compilation of IEEE Standard Computer Glossaries. IEEE Press, 1991.
- [20] C. Simard, "Normalisation de la formation en ligne, Enjeux, tendances et perspectives", document d'orientation stratégique, préparé pour l'Agence universitaire de la francophonie (AUF), Bureau Amérique du Nord, NordSud.org, 2002.
- [21] Livre Blanc : "Architecture Orientée Services (SOA) Une politique de l'interopérabilité", Mars 2005.
- [22] I. Madjarov, " Des services web pour le e-Learning". e-IT, Premier numéro <http://revue-eti.net/document.php?id=354>, 2005.
- [23] D. Aleksandar, S. Krassen, "Web-service architecture for tools supporting life-long e-Learning platforms". Proceedings of the 5th International TEN Competence Open Workshop, Stimulating Personal Development and Knowledge Sharing, 2008.
- [24] A. Derycke, V. Chevrin and J. Rouillard, "Intermédiations Multicanales et Multimodales pour l'E-Formation: l'Architecture du Projet Ubi-Learn", Actes de la Conférence EIAH 2005, Montpellier, ATIEF, INRP (eds), 2005.
- [25] S. GEAY, P. Repetto and S. Vicard, "Les Architectures Orientées Services". Travaux d'Etudes de Licence d'Informatique, 2005.
- [26] V. Monfort, S. Goudeau, "Web services et l'interopérabilité des SI: WS-I, WSAD / J2EE, Visual Studio.NET et BizTalk", Dunod, 2004.
- [27] S. Rampacek, "Sémantique, interactions et langages de description des services web complexes", doctoral thesis, l'Université de Reims Champagne, 2006.
- [28] J.M. Chauvet, "Services Web avec SOAP, WSDL, UDDI, ebXML...", Eyrolles, Paris, 2002.
- [29] N. Arenaza, "Composition semi-automatique de Services Web". Rapport de Projet de Master, Ecole Polytechnique Fédérale de Lausanne, 2006.
- [30] A. Albreshne, P. Fuhrer, J. Pasquier, "Web Services Orchestration and Composition: Case Study of Web services Composition". Working paper, 2009.
- [31] M. Khalidi Idrissi, F. Merrouch, S. Bennani, "Analyse des situations e-learning : abstraction et modélisation". In the proceedings of SIIE '09, Hammamet, Tunisia.2009
- [32] <http://fr.wikipedia.org>
- [33] Angela Biasiotti M., Fernandez-Barrera M. (2009). Enriching thesauri with ontological information: Eurovoc thesaurus and DALOS domain ontology of consumer law, 3rd Workshop on Legal Ontologies and Artificial Intelligence Techniques joint with, LOAIT '09, Barcelona, Spain.
- [34] Berners-Lee T.; Hendler J.; Lassila O.(2001). The semantic web, A new form of web content that is meaningful to computers will unleash a revolution of new possibilities. Scientific American, pages 35–43.
- [35] Bestgen Y. (2004). Analyse sémantique latente et segmentation automatique des textes ” Actes des 7es Journées internationales d'Analyse statistique des Données Textuelles, Louvain-la-Neuve, Presses universitaires de Louvain : 172-173.
- [36] Boutet M., Canto A., Roux E. (2005). Plateforme d'étude et de comparaison de distances conceptuelles, Rapport de Master, Ecole Supérieure En Sciences Informatiques, Université Nice Sophia-Antipolis.

- [37] Charlet J. (2002). Ontologie, STIM/DSI/AP-HP & Université. Paris 6 & groupe « Terminologie et Intelligence Artificielle » Séminaire ISDN/Web sémantique.
- [38] Corby O. (2004). Modélisation des Connaissances et Web sémantique : Ontologie, INRIA, Sophia Antipolis, cours essai <http://www-sop.inria.fr/acacia/cours/essi2004/index.html/ontologie2.ppt>
- [39] Hernandez N. (2005), Ontologie de domaine pour la modélisation du contexte en recherche d'information. Doctoral thesis, Paul Sabatier University, Toulouse, p63.
- [40] Kara Terki H. ; Chikh A. (2007). Patterns d'analyse pour l'ingénierie des besoins en e-learning , Rapport de Magister, Université de Tlemcen, Faculté des sciences de l'ingénieur.
- [41] Lgarch S.; Idrissi M. K. ; Bennani S. (2010). Reinforcing semantic classification of message based on LSA, The third edition of the International Conference on Web and Information Technologies, 16-19 June ISBN 978-9954-9083-0-3, Marrakech, Morocco.
- [42] Lgarch S.; Idrissi M. K. ; Bennani S. (2010). Toward a use of ontology to reinforcing semantic classification of message based on LSA, in the proceedings of ICEEEL '10. Paris, France.
- [43] Saadani L. ; Bertrand-Gastaldy S. (2000). Cartes conceptuelles et thésaurus : essai de comparaison entre deux modèles de représentation issus de différentes traditions disciplinaires, Canadian Association for Information Sciences, Proceedings of the 28th Annual Conference.
- [44] Zargayouna H. (2005). Indexation sémantique de documents XML, Doctoral thesis, Paris-Sud university, Paris, France.
- [45] S. Lgarch, M. Khalidi Idrissi et S. Bennani, « The improvement of the semantic classification tool to a SOA to ensure a better tutoring », International Journal of Computer Science Issues , Vol. 8, Issue 3, pp 172-181, 2011.
- [46] J. Searle, J. Brennan, "General Interoperability Concepts. In Integration of Modelling and Simulation", pp. 3-1 – 3-8. Educational. Notes RTO-EN-MSG-043bis, Paper 3. Neuilly-sur-Seine, France: RTO. Available from: <http://ftp.rta.nato.int/public/PubFullText/RTO/EN/RTO-EN-MSG-067/EN-MSG-067-03.pdf>, 2007
- [47] <http://www.w3.org>
- [48] http://greco.grenet.fr/documents/_tutorat_outils_de_communication.pdf